

# EME op 10 GHz voor iedereen?!

**Moonbouncing met een 1,2 m schotel antenne**

EME gegevens, Systeem overzicht,  
Hard- en Software, Resultaten

# Indeling van de presentatie

- Inleiding
- Deel 1: algemene beschrijving
  - EME gegevens
  - Systeem overzicht
  - Operating
- Deel 2: Enkele details
  - Radar formule toepassen
  - Details van het Q65 communicatie protocol
  - Dish met straler nader bekijken
  - Antenne tracker unit details

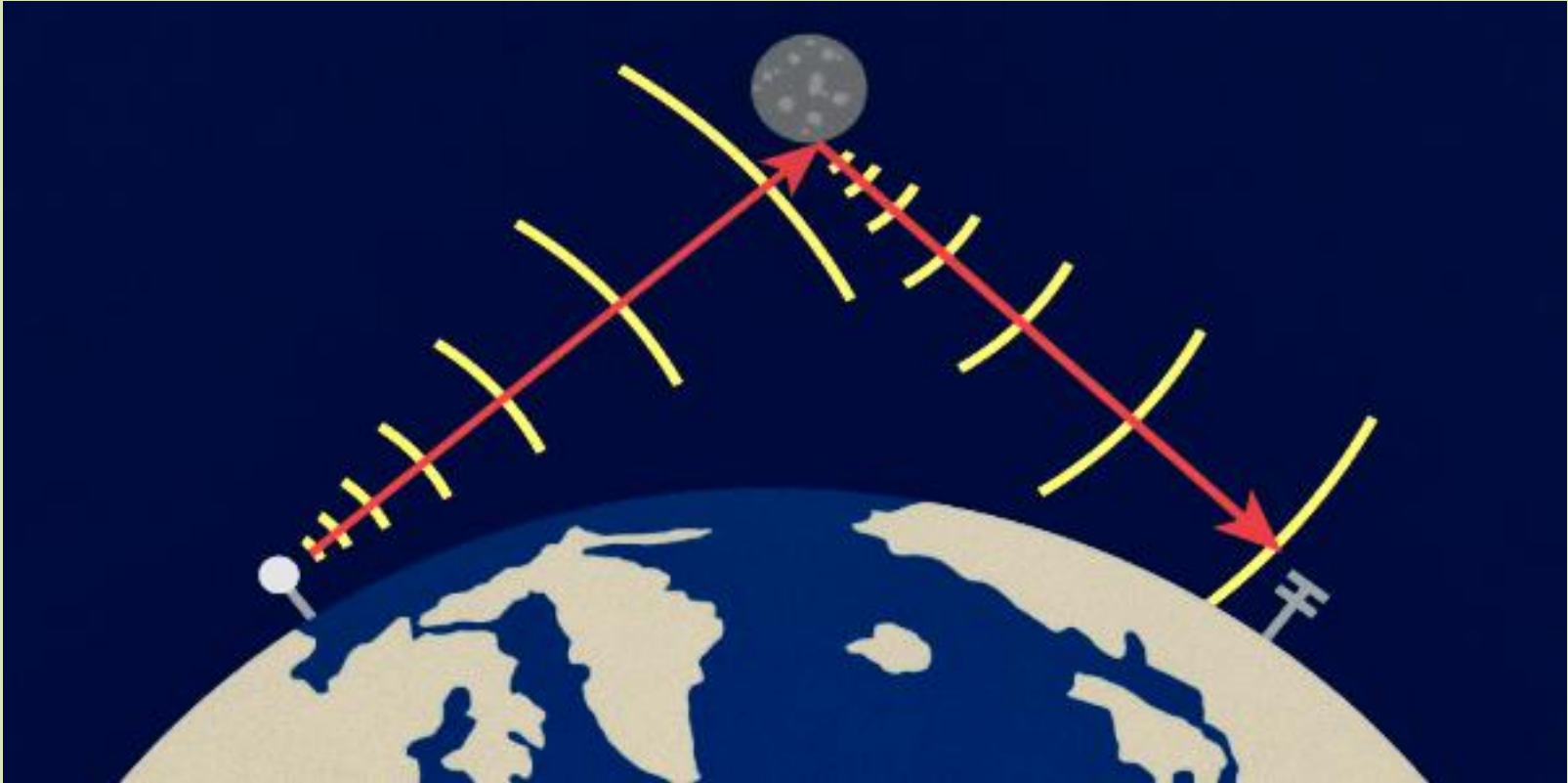

# Enkele EME gegevens (1)

Afstand Aarde - Maan: 360.000 – 405.000 km

De maanreflectiefactor: ~ 7%

Traject demping op 10 GHz: ~ 288 .... 290 dB

Moonbounce Echo Delay: ~ 2,5 seconde



# Enkele EME gegevens (2)

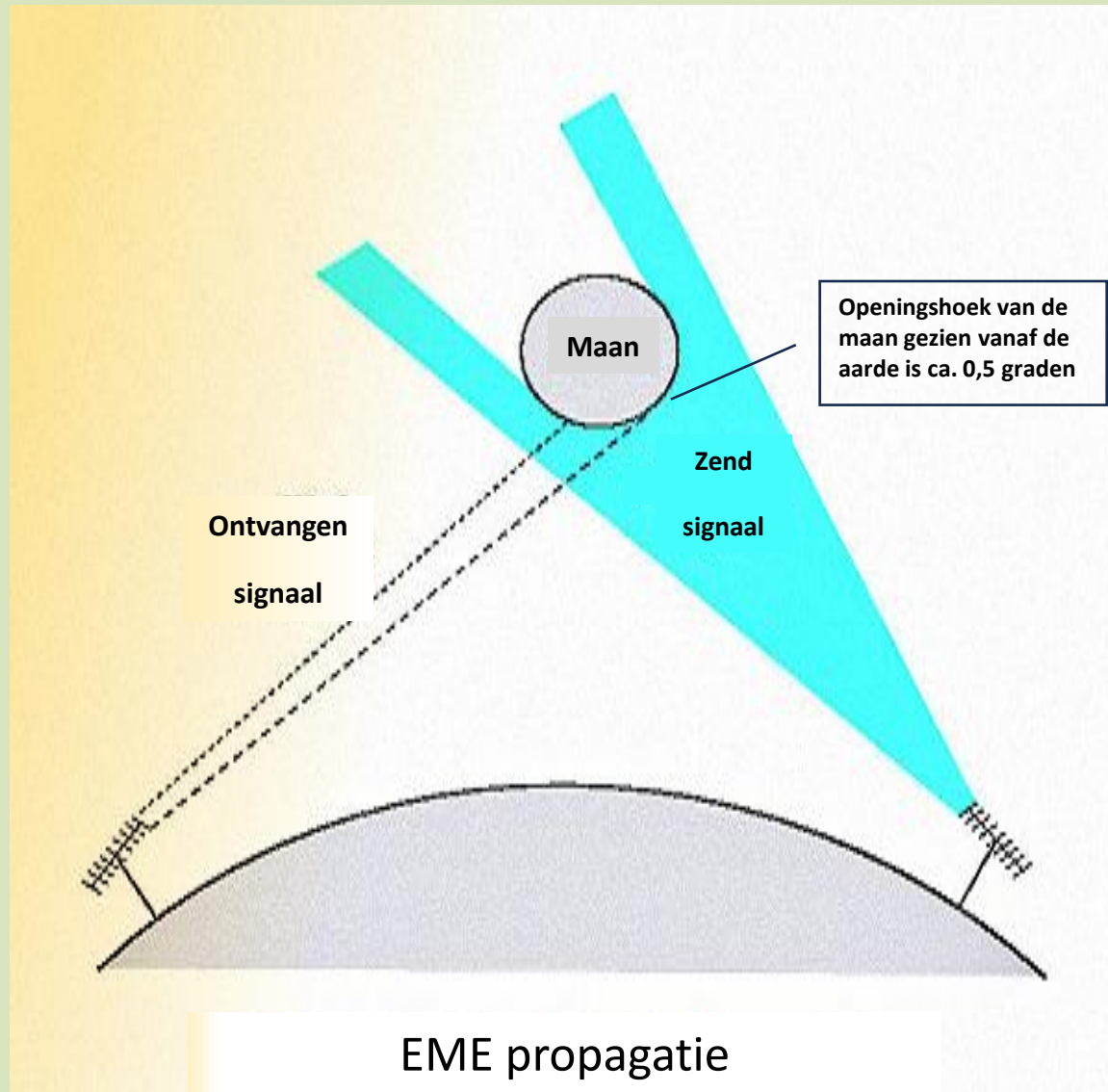

# Enkele EME gegevens (3)

## Polarisatie

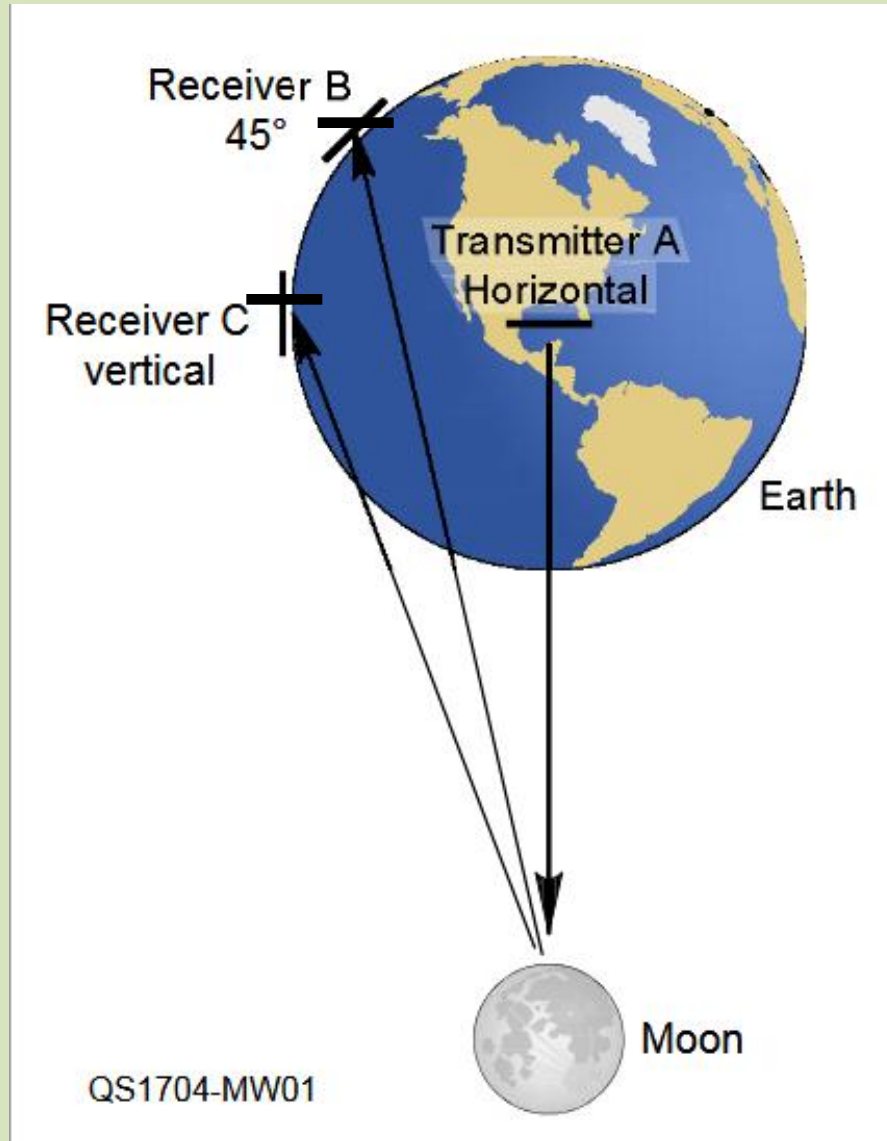

# Enkele EME gegevens (4)

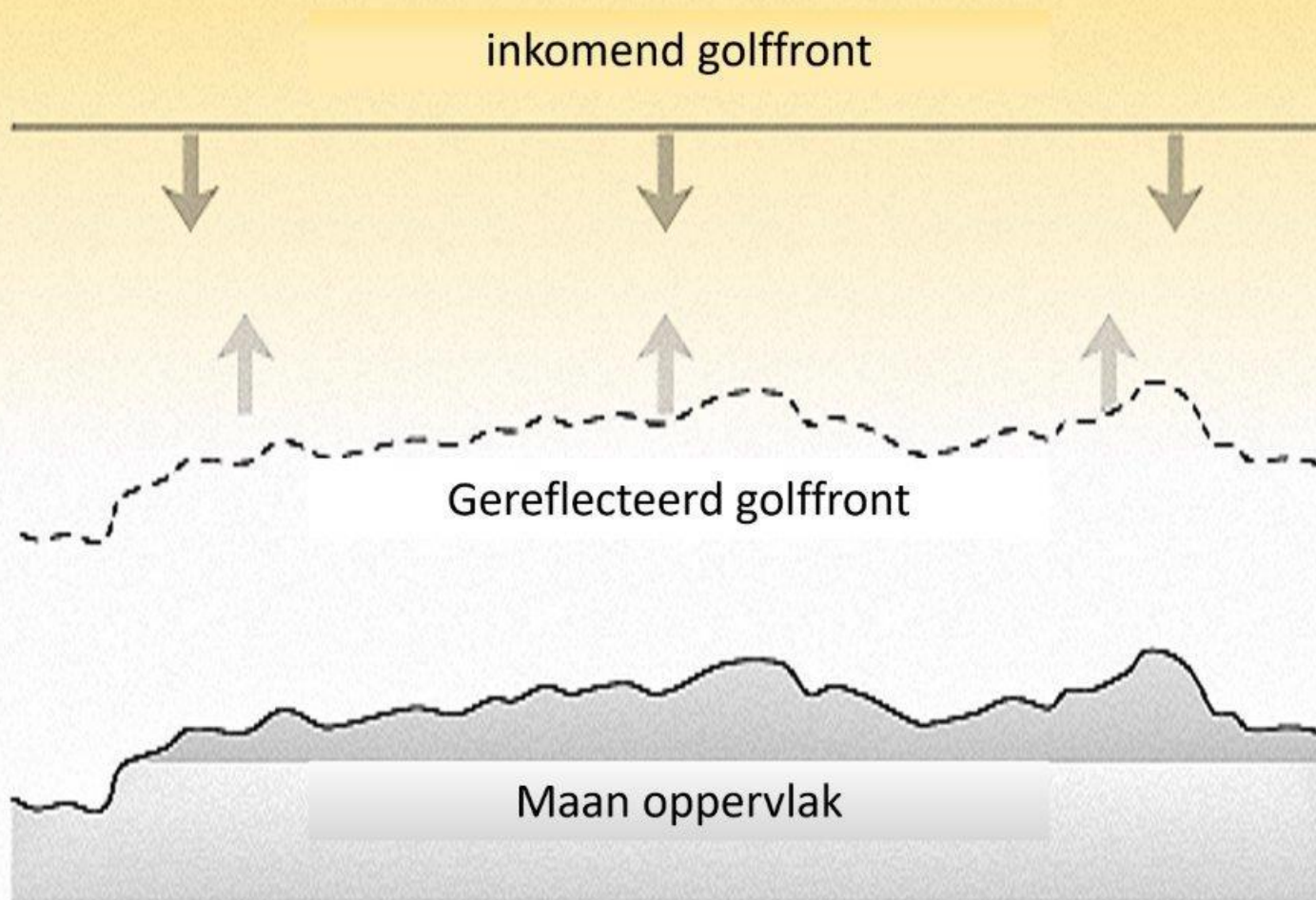

# Enkele EME gegevens (5)

- $f_{rx} = f_{tx} \frac{C}{C + V}$  ;  $f_{rx} = f_{tx} \left[ \frac{C}{C + V_{tx}} \right] \left[ \frac{C}{C + V_{rx}} \right]$
- Er treedt een Doppler verschuiving op en deze kan worden berekend
- De Doppler verschuiving is op elke plaats op aarde verschillend
- De 'basic' Doppler verschuiving op 10 GHz kan meer dan  $\pm 20$  kHz bedragen
- De maan roteert, maakt kleine bewegingen en de oppervlakte van de maan is niet egaal hierdoor ontstaat een 'smear' Doppler verschuiving (signaal overbreeding) tot maximaal 200 Hz: de 'Doppler smear' (libration spreading) is specifiek voor SHF/EHF verbindingen

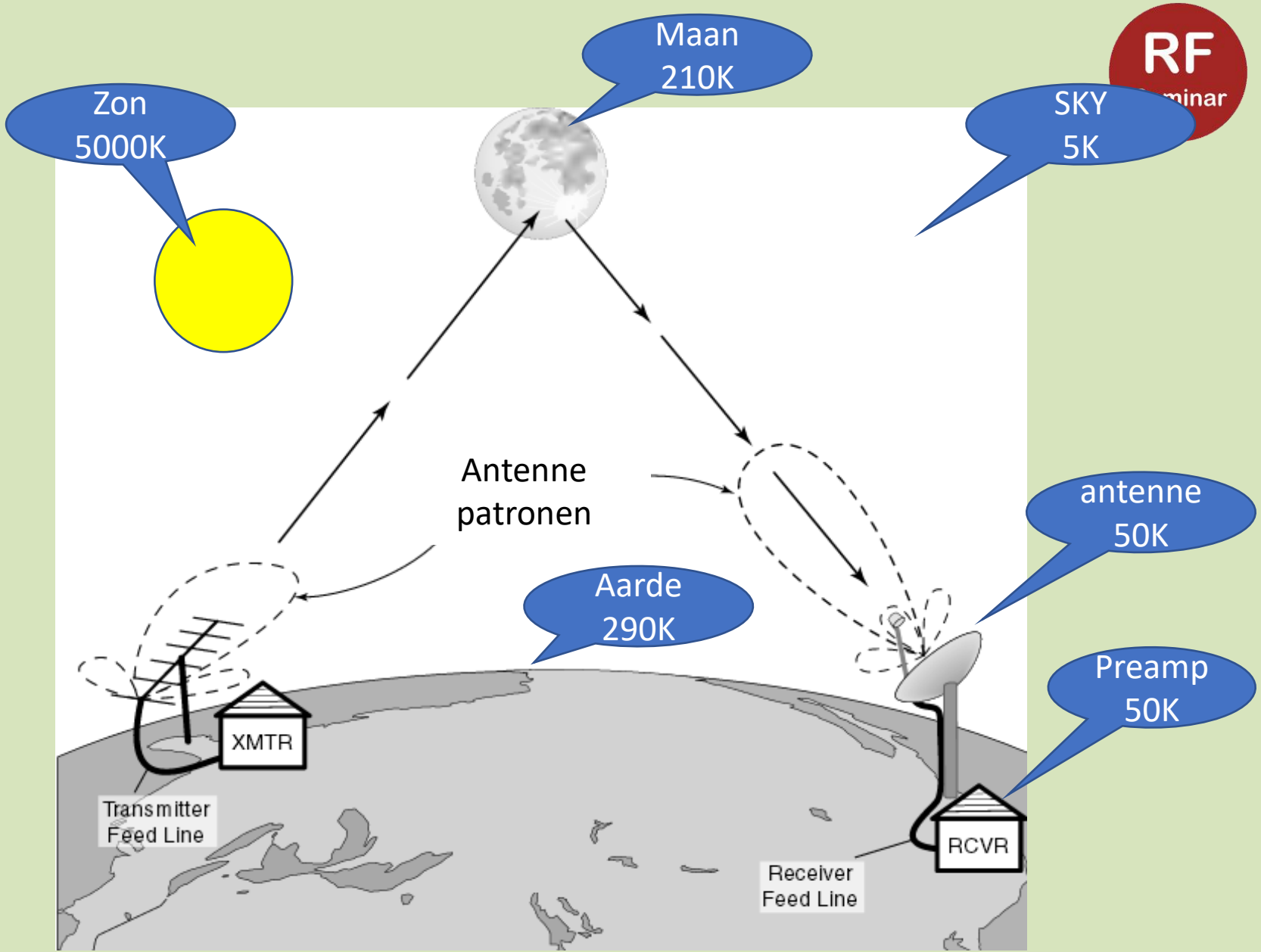

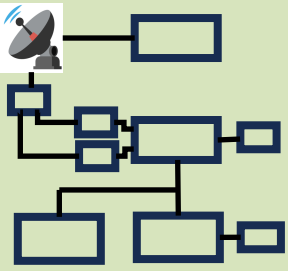

# Overzicht EME systeem

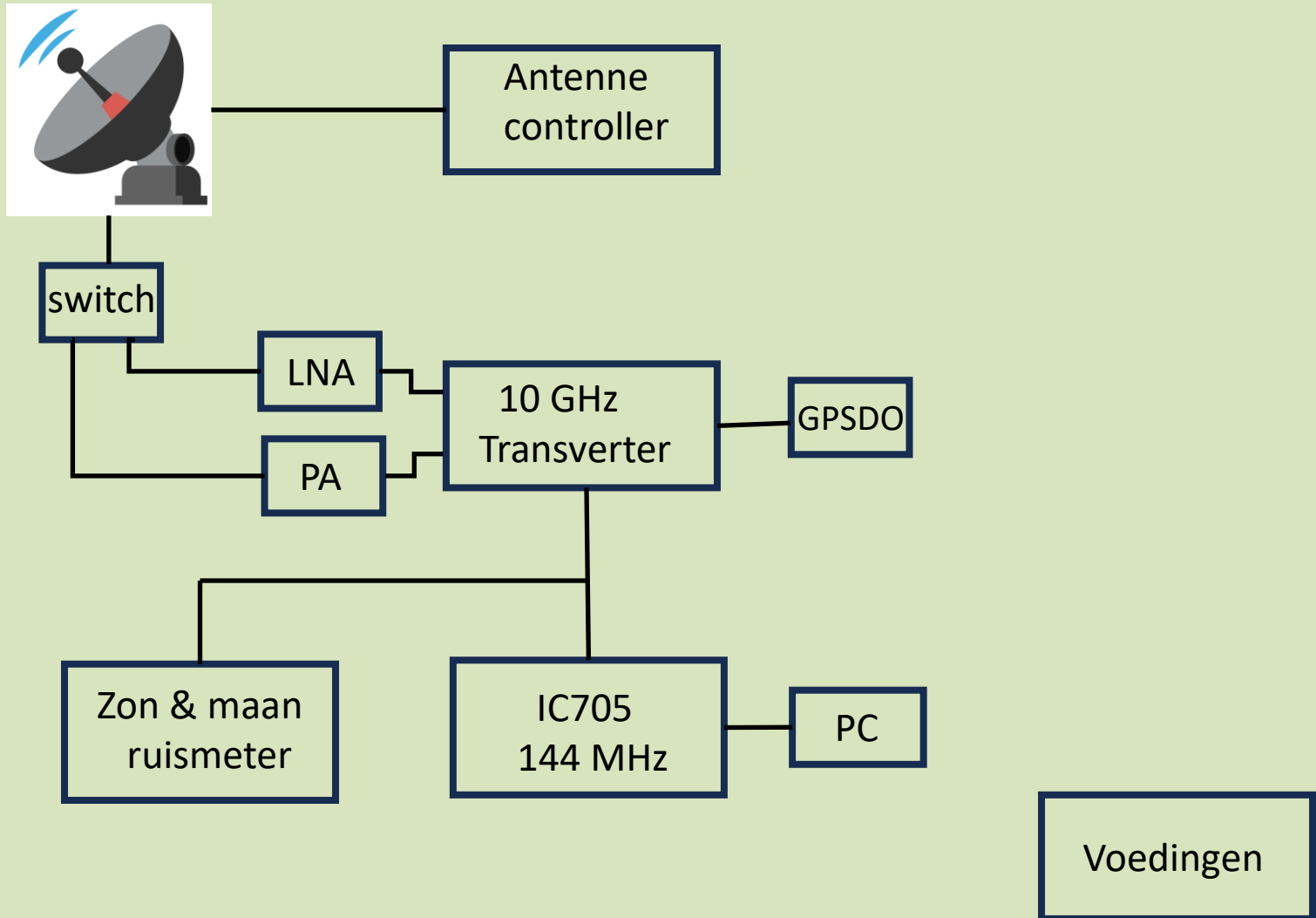

Axial or  
Front feed

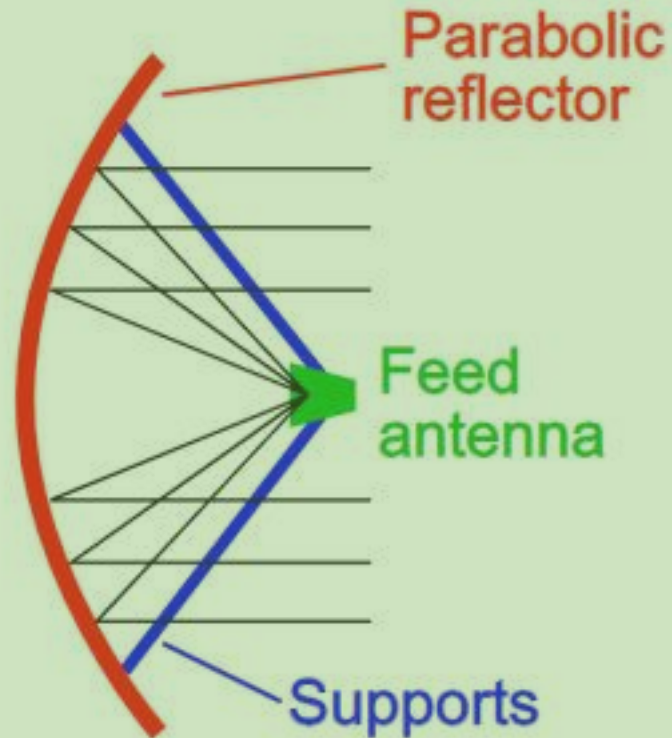

Off-axis or  
Offset feed

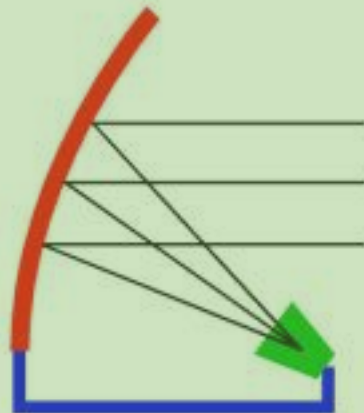

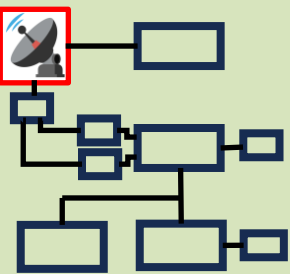

# Offset schotel

**Laminas OFC 1200 Afmetingen: 1190 x 1298**

**Gain: 40 dBi, Gewicht: ca 7 kg**



Wifi Calculations for Parabolic Dish with Offset Feedhorn

Inputs

Enter Frequency	10368	MHz
Diameter of large axis of dish	1300	mm
Diameter of small axis of dish	1200	mm
Depth of dish at deepest pt	120	mm
Distance of deepest pt from bottom edge along large axis	550	mm

Units (all entries)  inches  mm

Calculate

Save to File

Exit

The Focal Length is 668,19 mm.

This offset reflector is a section of a full parabola with a diameter of 2375,89 mm whose vertex is at the bottom edge of the offset reflector. The full parabola has an  $f/D = 0,28$ , which determines criticality of focal length.

The focal point of the dish is 668,19 mm from the bottom edge of the reflector and 1196,19 mm from the top edge of the reflector.

For operation with the main beam on the horizon with the feed at the bottom, the dish must be tilted forward so that the large axis is 66,04 degrees above horizontal.

Illumination angle for feed = 83,27 degrees on the large axis and 85,88 degrees on the small axis. A feedhorn with a 3 dB beamwidth of 50,28 degrees is needed, equivalent to the feed for a conventional dish with  $f/D = 0,64$ .

Gain at 50% efficiency = 39,29 dBi. If you do really well, you might get 60% efficiency for a gain = 40,09 dBi.

$\Psi$  (de 3 dB openingshoek van de antenne)  $\Psi = 70 \lambda / D$  ( $\lambda$  in meters,  $D$  in meters)

Voor de 3 cm amateurband 10368 MHz is  $\Psi \sim 1,7$  graden voor een 120 cm dish



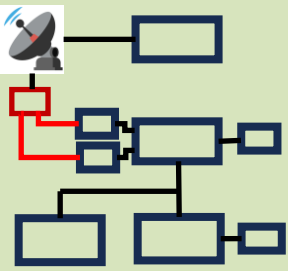

# Golfpijp en omschakel relais

Het verlies in een standaard golfpijp (type **WR-90**, vaak gebruikt voor X-band) op **10 GHz** is zeer laag in vergelijking met coaxkabels. Het typische dempingsverlies ligt rond de **0,10 tot 0,13 dB per meter**

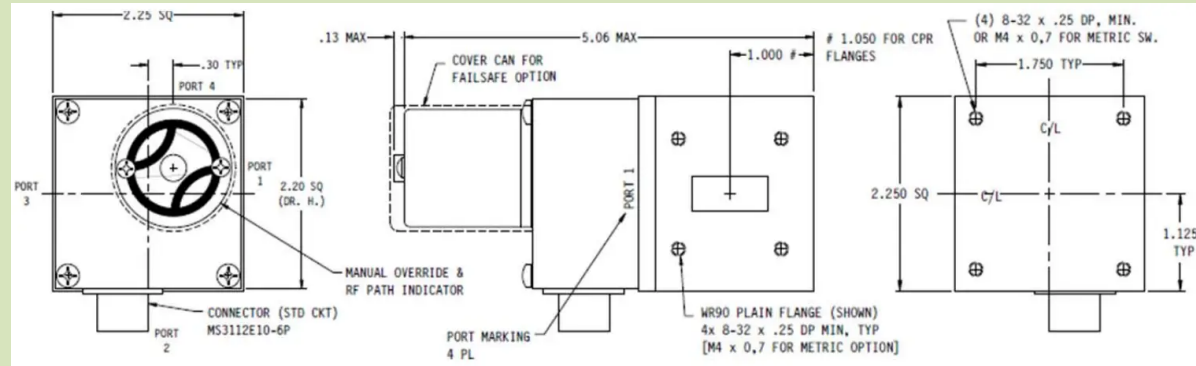

**WR90 golfpijp schakelaar**  
**Verlies kleiner dan 0,05 dB**

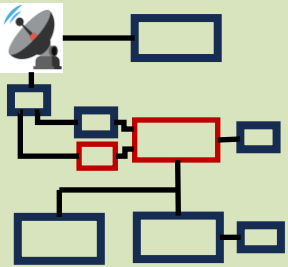

# 10 GHz transverter



DB6NT 10 GHz transverter MK2

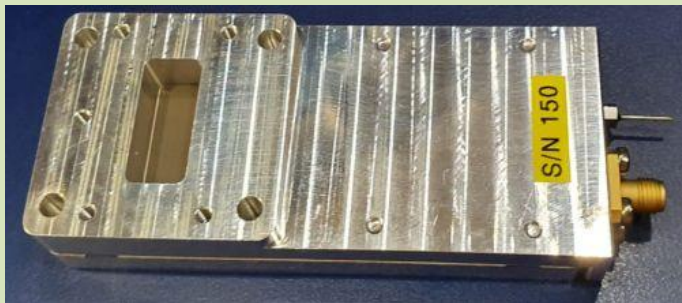

DU3T-XLNA;  
Noise figure : 0.6 dB  
Gain: 29 dB

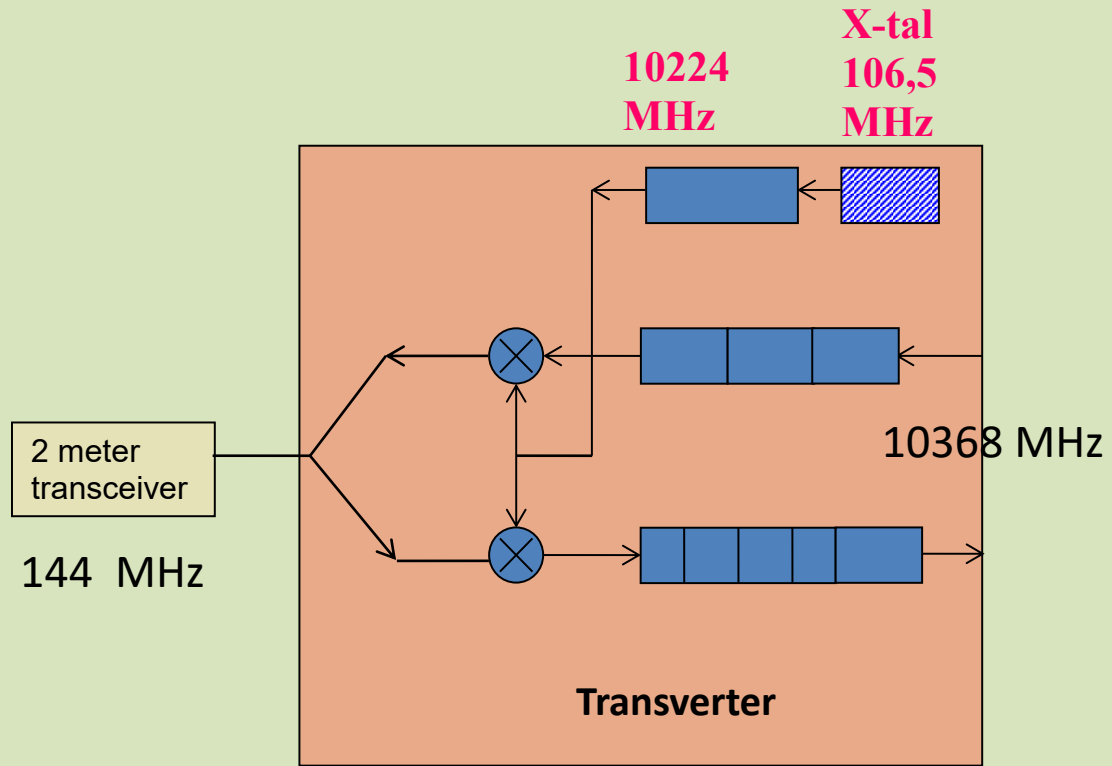

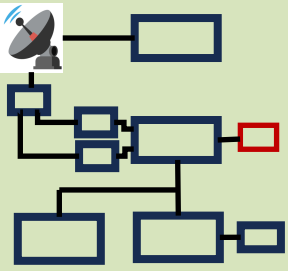

# Gelockte 10 GHz transverter



GPSDO

GPS antenne

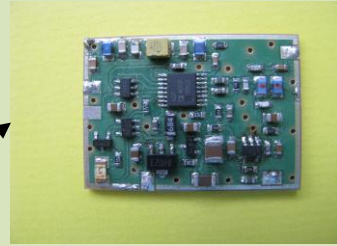

PLL print PE1PFW

10 MHz

10224 MHz  
X-tal  
106,5 MHz

2 meter transceiver

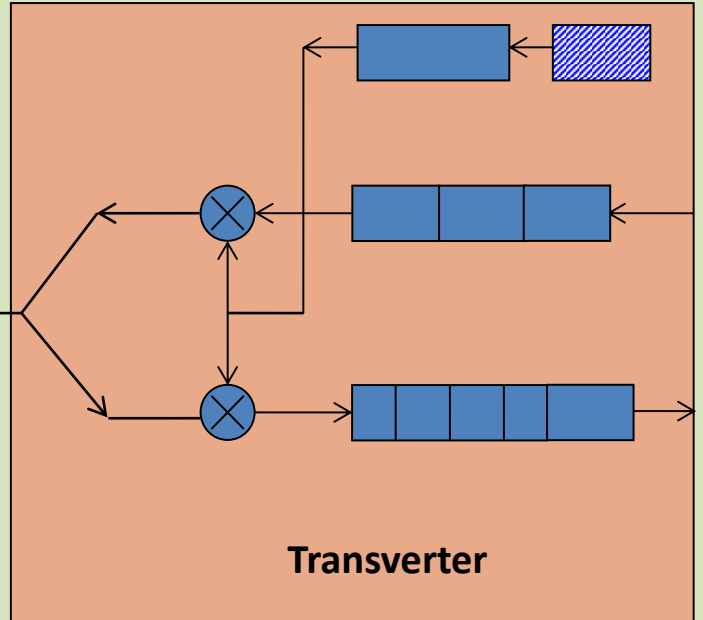

Transverter

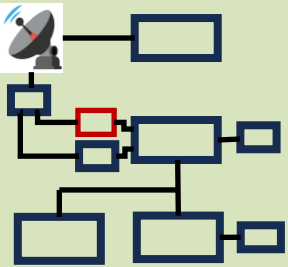

# De Eindtrap

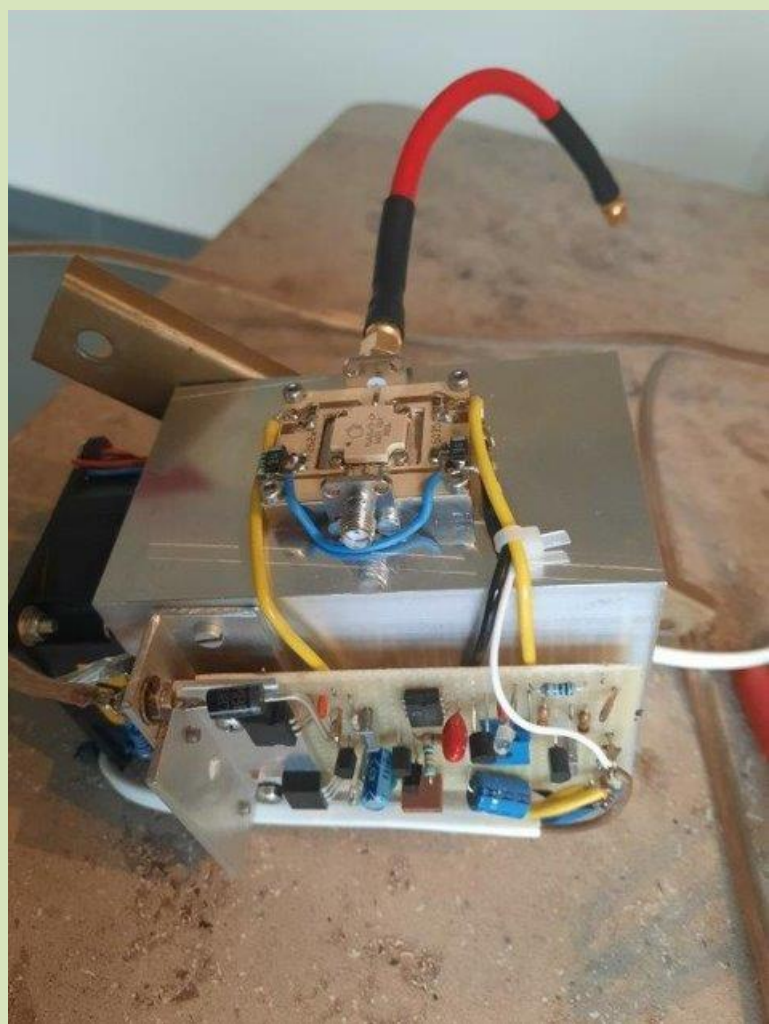

**GaN**



## Specs:

Frequency Range: 10 – 11 GHz  
PSAT: 45 dBm @ PIN = 18 dBm  
PAE: > 41 % @ PIN = 18 dBm

32 Watt out met 80 mW  
in en 30 volt voeding

Dank aan  
Harke,  
PA0HRK



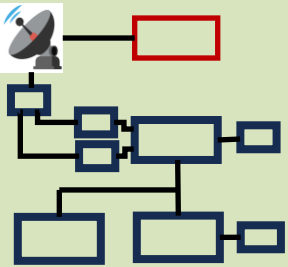

# EME tracking system

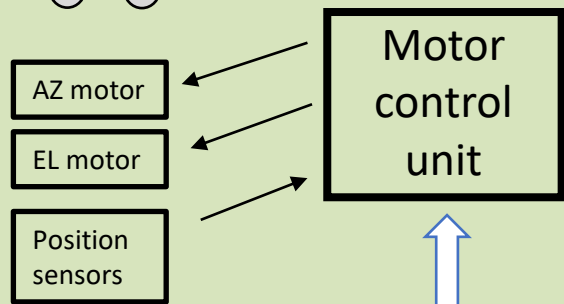
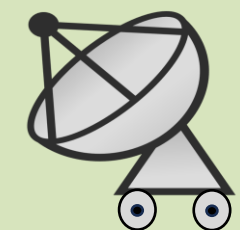

15 volt

## Antenna tracking unit

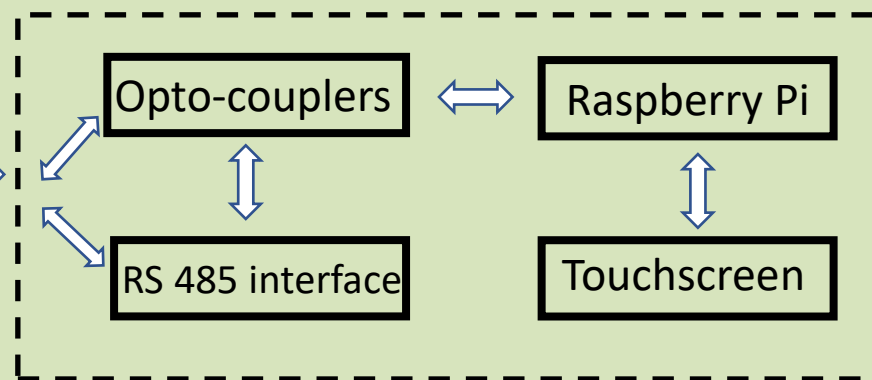

WIFI

12 volt

# Hardware onderdelen

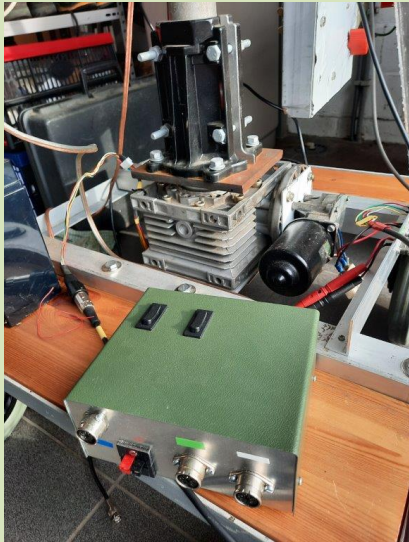

Azimut rotor

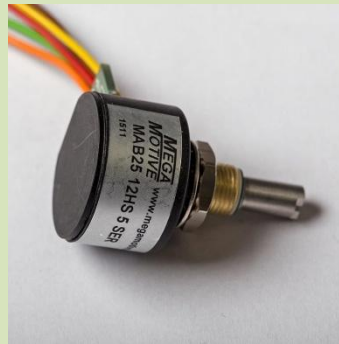

Hall positie opnemer

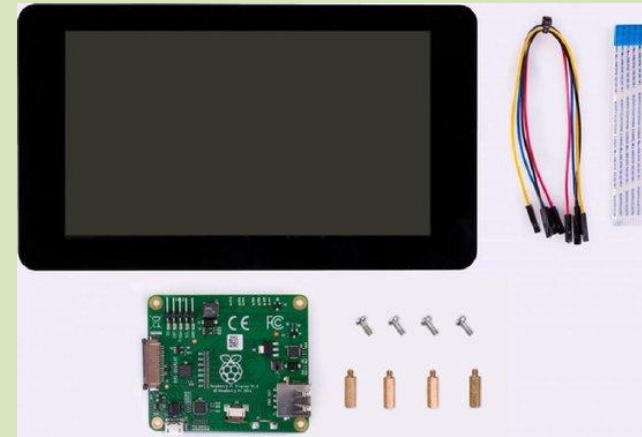

Raspberry Pi 3B  
met aanraak  
scherm



actuator



Elevatie opnemer

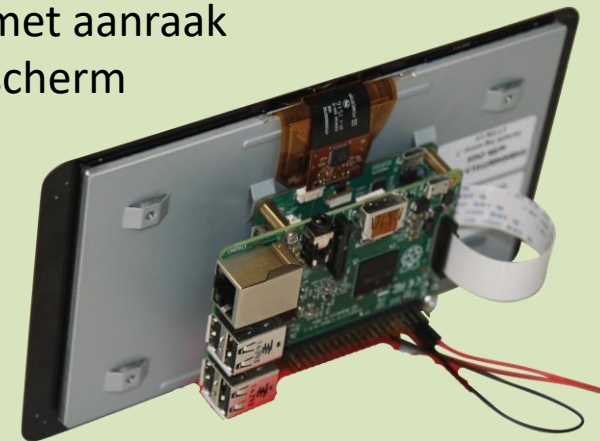

Antenna controller.DN4CDU V0.2

DATE: Sat, 07 Feb 2026 UTC: 15:47:28 LT: 16:47:28

EL +

AZ - fast AZ +

EL -

positions	AZ	EL
ANTENNA:	0.0	0.0
MOON:	350.9	-54.0
SUN:	235.4	7.1

Moontracker

calibrate antenna

stop

Manual state tracking is off

clear park quit

UART: no incoming data received  
UART: no incoming data received  
UART: no incoming data received

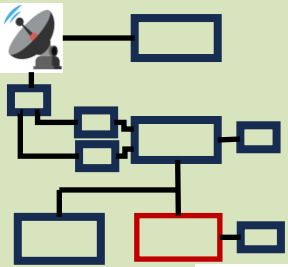

# De Radio IC705



**All-Mode SDR QRP Transceiver HF/50  
MHz/144 MHz/430 MHz**

# Keuze overweging

- Geschikt als achterzet voor microgolf transverters vanwege 2 m en 70 cm en regelbaar uitgangsvermogen
- Volledige control over USB
- Audio over USB
- Frequentie stabiliteit is prima (echter geen 10 MHz ingang voor locking)
- Prijs
- Geschikt voor portabel gebruik (accu)

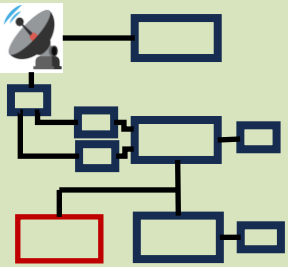

# Zon- en maanruismeter

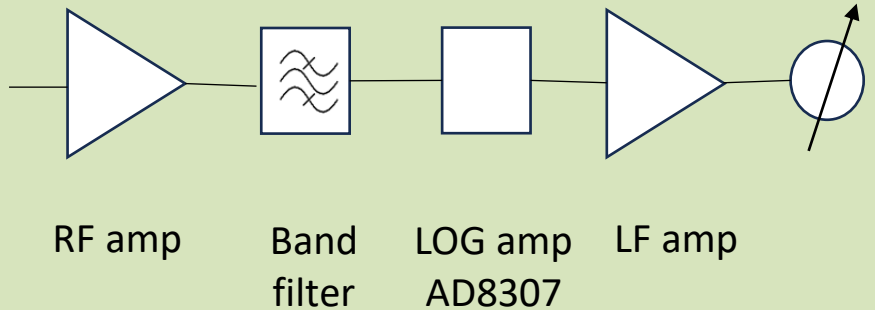

**Note: Ook een SDR (bijvoorbeeld een RTL dongle) met het programma spectravue is zeer goed bruikbaar voor dit type ruismetingen**

# In bedrijfstelling

- **Systeem test**
  - Alle belangrijke functies testen vooral besturing en calibratie van AZ en EL
- **Optimaliseren**
  - Feed positie bepalen (touwtjes methode, spiegel)
  - Zon- en maanruis meten (bij 120cm schotel  
~ 10 dB zonneruis en 0,5 dB maanruis)
- **WSJT - x installeren en aanpassen**
  - Tijd synchronisatie
  - WSJT met radio laten werken
- **DL0SHF beluisteren en decoderen**

# Operating (1)

- **HB9Q chat**
- **WSJT - x instellen**
  - Mode bv Q65 60D
  - Doppler mode instellen (bv CFOM)
  - Zend/ontvang cyclus
- **Ontvangen / Zenden**
- **AZ/EL regelmatig checken**
  - Maximum maanruis

# Operating (2)

- HB9Q chat

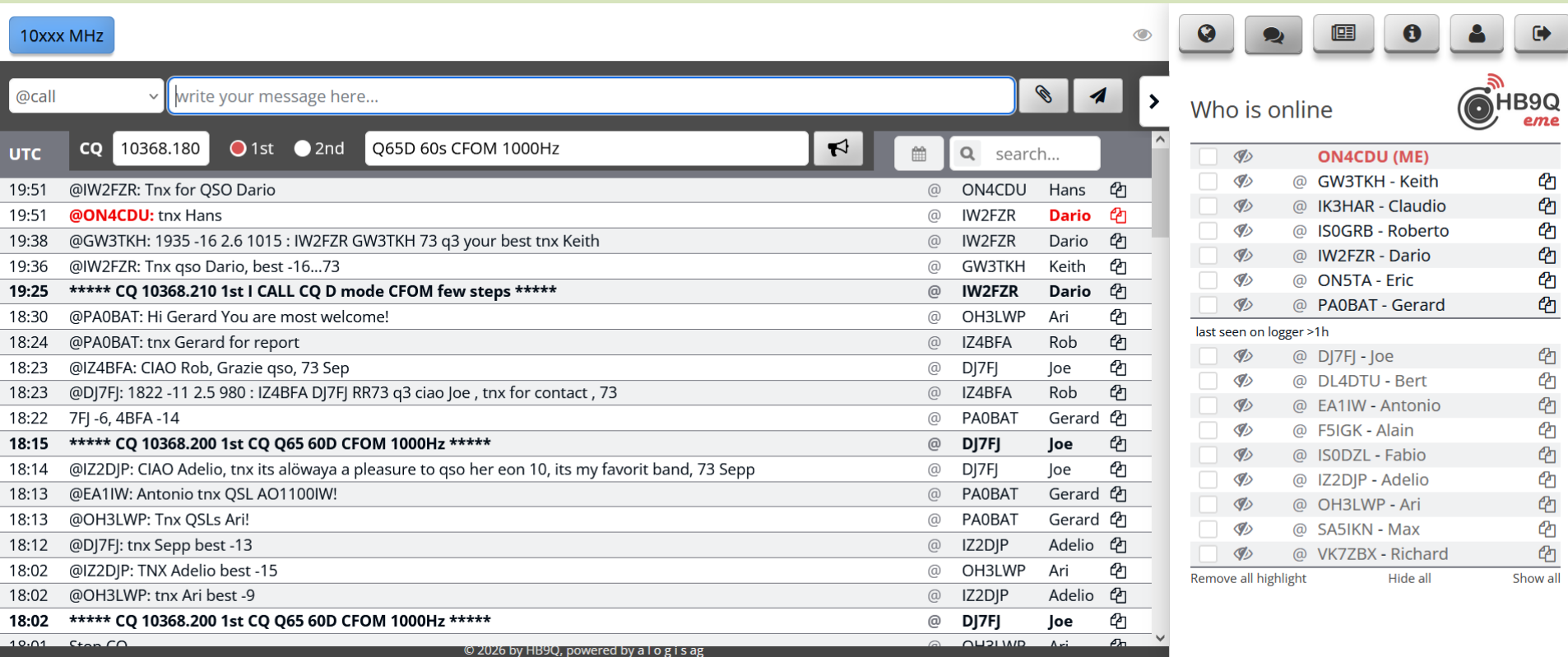

The screenshot displays the HB9Q chat application interface. At the top, there's a frequency display showing '10xxx MHz'. Below it is a message input field with a placeholder 'write your message here...'. The main chat log shows a series of messages with timestamps, call signs, and content. A 'Who is online' sidebar on the right lists active users with their call signs and names. The interface includes various control buttons like mute, volume, and search.

**Chat Log:**

UTC	CQ	10368.180	1st	2nd	Q65D 60s CFOM 1000Hz	Search...
19:51	@IW2FZR:	Tnx for QSO Dario	@ ON4CDU	Hans		
19:51	@ON4CDU:	tnx Hans	@ IW2FZR	Dario		
19:38	@GW3TKH:	1935 -16 2.6 1015 : IW2FZR GW3TKH 73 q3 your best tnx Keith	@ IW2FZR	Dario		
19:36	@IW2FZR:	Tnx qso Dario, best -16...73	@ GW3TKH	Keith		
19:25	*****	CQ 10368.210 1st I CALL CQ D mode CFOM few steps *****	@ IW2FZR	Dario		
18:30	@PA0BAT:	Hi Gerard You are most welcome!	@ OH3LWP	Ari		
18:24	@PA0BAT:	tnx Gerard for report	@ IZ4BFA	Rob		
18:23	@IZ4BFA:	CIAO Rob, Grazie qso, 73 Sep	@ DJ7FJ	Joe		
18:23	@DJ7FJ:	1822 -11 2.5 980 : IZ4BFA DJ7FJ RR73 q3 ciao Joe , tnx for contact , 73	@ IZ4BFA	Rob		
18:22	7FJ -6, 4BFA -14		@ PA0BAT	Gerard		
18:15	*****	CQ 10368.200 1st CQ Q65 60D CFOM 1000Hz *****	@ DJ7FJ	Joe		
18:14	@IZ2DJP:	CIAO Adelio, tnx its alöwaya a pleasure to qso her eon 10, its my favorit band, 73 Sepp	@ DJ7FJ	Joe		
18:13	@EA1IW:	Antonio tnx QSL AO1100IW!	@ PA0BAT	Gerard		
18:13	@OH3LWP:	Tnx QSLs Ari!	@ PA0BAT	Gerard		
18:12	@DJ7FJ:	tnx Sepp best -13	@ IZ2DJP	Adelio		
18:02	@IZ2DJP:	TNX Adelio best -15	@ OH3LWP	Ari		
18:02	@OH3LWP:	tnx Ari best -9	@ IZ2DJP	Adelio		
18:02	*****	CQ 10368.200 1st CQ Q65 60D CFOM 1000Hz *****	@ DJ7FJ	Joe		
18:01	Stop CQ		@ OH3LWP	Ari		

**Who is online:**

- ON4CDU (ME)
- @ GW3TKH - Keith
- @ IK3HAR - Claudio
- @ IS0GRB - Roberto
- @ IW2FZR - Dario
- @ ON5TA - Eric
- @ PA0BAT - Gerard

last seen on logger >1h

- @ DJ7FJ - Joe
- @ DL4DTU - Bert
- @ EA1IW - Antonio
- @ F5IGK - Alain
- @ IS0DZL - Fabio
- @ IZ2DJP - Adelio
- @ OH3LWP - Ari
- @ SASIKN - Max
- @ VK7ZBX - Richard

Remove all highlight      Hide all      Show all

© 2026 by HB9Q, powered by a l o g i s a g

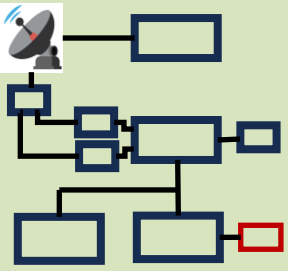

# Operating (3)

## WSJT-X



**2026 feb 24**

UTC: 20:14:38

Az: 241.5

El: 54.1

SelfDop: -9917

Width: 108

Delay: 2.43

DxAz: 256.5

DxEl: 52.2

DxDop: -11444

DxWid: 113

Dec: 26.8

SunAz: 292.6

SunEl: -28.8

Freq: 10368.2

Tsky: 3

Dpol: -12.5

MNR: 0.9

Dist: 364956

Dgrd: -0.5

Single-Period Decodes					Average Decodes				
UTC	dB	DT	Freq	Message	UTC	dB	DT	Freq	Message
1944	-15	2.6	980	CQ IW2FZR JN46 q3	200600	Tx	1000	1000	CQ ON4CDU JO20
1946	-15	2.8	979	CQ IW2FZR JN46 q3	200800	Tx	1000	1000	ON5TA ON4CDU -12
1948	-15	2.8	987	ON4CDU IW2FZR -15 q3	2009	-12	2.6	976	ON4CDU ON5TA R-13 q3
1950	-15	2.8	980	ON4CDU IW2FZR RR73 q3	201000	Tx	1000	1000	ON5TA ON4CDU RRR
2007	-12	2.6	974	ON4CDU ON5TA JO20 q0	2011	-12	2.6	974	ON4CDU ON5TA 73 q3
2009	-12	2.6	976	ON4CDU ON5TA R-13 q3	201237	Tx	1000	1000	CQ ON4CDU JO20
2011	-12	2.6	974	ON4CDU ON5TA 73 q3	2013	-19	2.6	982	ON4CDU IZ4BFA JN54 q2
2013	-19	2.6	982	ON4CDU IZ4BFA JN54 q2	201400	Tx	1000	1000	IZ4BFA ON4CDU -19

'astronomical window'

# Doppler

- **Echo**

- TX op de 'Sked frequentie'
- Rx op de 'Sked frequentie' plus de 'self Doppler'

- **Full doppler to DX**

- **Antwoorden van een station dat CQ roept op een aangekondigde frequentie (sked frequentie)**
  - Tx on Sked frequentie + (Self Doppler - Dx Doppler)
  - Rx on Sked frequentie + Dx Doppler
- **Antwoorden van een station dat je hoort op een rx frequentie**
  - Tx op Rx frequentie – self doppler
  - Rx op Rx frequentie

- **CFOM (Constant Frequency On Moon)**

- Tx on Sked -  $\frac{1}{2}$  self doppler ("virtual" Tx op de sked frequentie op de maan)
- Rx on Sked +  $\frac{1}{2}$  self doppler
- Elk station compenseert dus voor zijn doppler verschuiving; hierdoor kan iedereen meeluisteren en zijn random QSO's ook veel eenvoudiger

# Operating ....



# Enkele resultaten

2023-09-06,08:23:00,2023-09-06,08:28:57,PA0PLY,JO32,10368.211500,Q65,-15,-14,20 W,,,  
2023-09-06,09:37:00,2023-09-06,09:37:00,OK2AQ,JN89,10368.171500,Q65,-18,-22,,,,  
2023-09-06,09:48:58,2023-09-06,09:48:58,LZ4OC,KN33,10368.201501,Q65,-19,-19,,,,  
2023-09-06,10:12:00,2023-09-06,10:15:01,IZ4BFA,JN54,10368.181530,Q65,-19,-19,,,,  
2023-09-07,07:49:00,2023-09-07,07:55:00,PE1CKK,JO22OF,10368.141500,Q65,-14,-18,,,,  
2023-09-07,07:57:00,2023-09-07,07:57:00,PE1CKK,JO22OF,10368.141500,Q65,-14,-18,,,,  
2023-09-07,08:37:00,2023-09-07,08:42:57,OK2AQ,JN89,10368.171000,Q65,-17,-19,,,,  
2023-09-09,09:51:00,2023-09-09,09:55:00,OZ1LPR,JO44,10368.161000,Q65,-05,-17,,,,  
2023-09-09,10:29:00,2023-09-09,10:33:00,GB2FRA,IO90,10368.170999,Q65,-06,-16,,,,  
2023-09-09,11:37:00,2023-09-09,11:42:00,K2UYH,FN20,10368.186003,Q65,-17,-19,,,,  
2023-09-09,13:15:00,2023-09-09,13:19:00,OK2AQ,JN89,10368.191100,Q65,-18,-19,,,,  
2023-09-09,13:33:00,2023-09-09,13:39:00,UR3VKC,KN68,10368.231000,Q65,-22,-23,,,,  
2023-09-10,09:49:00,2023-09-10,09:53:00,DL3WDG,JN68,10368.151000,Q65,-13,-17,,,,  
2023-09-10,09:57:00,2023-09-10,10:01:00,OK1KIR,JN79,10368.121000,Q65,-10,-14,,,,  
2023-09-10,10:15:00,2023-09-10,10:19:00,IW2FZR,JN46,10368.221000,Q65,-17,-17,,,,  
2023-09-10,10:42:00,2023-09-10,10:48:00,PE1CKK,JO22,10368.221000,Q65,-14,-18,,,,  
2023-09-10,12:11:00,2023-09-10,12:17:00,OH1LRY,KP11,10368.156000,Q65,-17,-20,,,,  
2023-09-10,12:59:00,2023-09-10,13:03:00,GB2FRA,IO90,10368.201000,Q65,-05,-16,,,,  
2023-09-10,13:34:00,2023-09-10,13:39:58,G4YTL,IO92,10368.240700,Q65,-16,-32,,,,  
2023-09-10,13:49:00,2023-09-10,13:53:00,OK1CA,JO70,10368.221000,Q65,-16,-16,,,,  
2023-09-10,14:11:00,2023-09-10,14:15:00,IK6CAK,JN72,10368.171000,Q65,-20,-21,,,,

# Echo

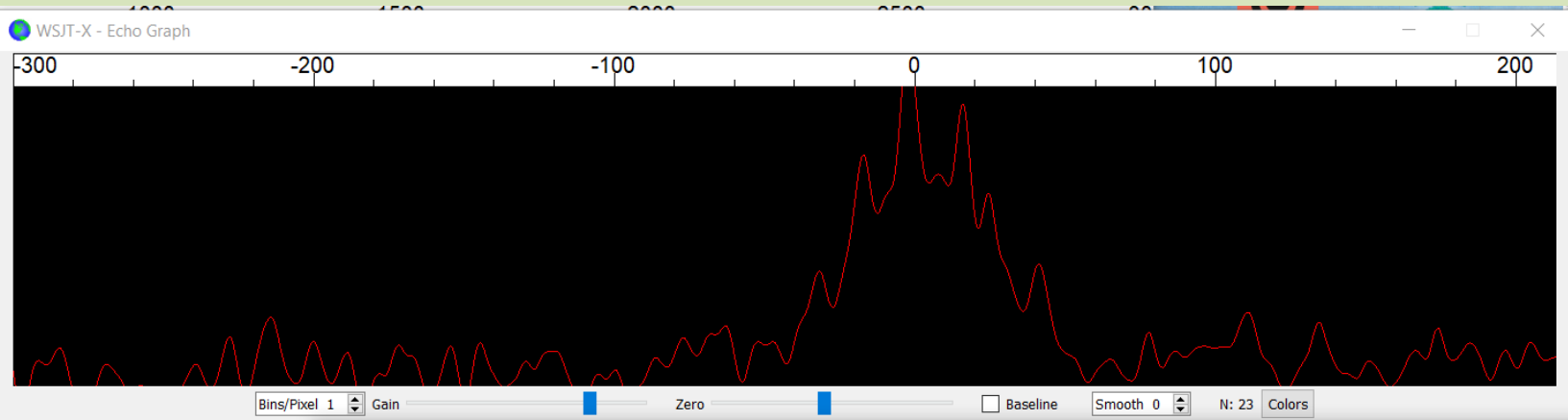

acer\_2  
20:38 3cm  
20:37 3cm  
20:36 3cm  
20:25 2cm

WSJT-X - Astronomical Data

2026 feb 24  
 TC: 20:38:44  
 z: 248.1  
 l: 50.8  
 elfDop: -11312  
 idth: 100  
 elay: 2.44  
 xAz: 261.5  
 xEl: 48.1  
 xDop: -12849  
 xWid: 105  
 ec: 26.8  
 unAz: 298.2  
 unEl: -32.2  
 eq: 10368.1  
 sky: 3  
 pol: -11.1  
 NR: 0.7  
 ist: 365178  
 grd: -0.5

Doppler tracking

- Full Doppler to DX Grid
- Own Echo
- Constant frequency on Moon
- On DX Echo
- Call DX
- None

Sked frequency

Rx: 10.368,100 000  
 Tx: 10.368,100 000

Press and hold the CTRL key to adjust the sked frequency manually with the rig's VFO dial or enter frequency directly into the band entry field on the main window.

Echo Mode

RIT 0 Hz  Dither

Tx Shift relative to Rx Sked Freq

Shift 0 MHz  Enable

WSJT-X v3.0.0-rc1

File Configurations View Filters Mode Decode Save Tools Help

UTC	Hour	Level	Doppler	Width	N	Q	DF	SNR	dBerr	DT	TS	EchoMsg
203736	20.6267	60.32	-11253	100.7	13	10	6	-16.8	0.5	0.10		
203742	20.6283	60.33	-11259	100.6	14	10	13	-16.7	0.5	-0.40		
203748	20.6300	60.21	-11265	100.6	15	10	-1	-17.0	0.5	0.30		
203754	20.6317	60.43	-11270	100.6	16	10	-1	-17.1	0.5	-0.50		
203800	20.6333	60.34	-11276	100.6	17	10	9	-17.0	0.5	0.40		
203806	20.6350	60.13	-11281	100.5	18	10	-3	-16.9	0.5	0.45		
203812	20.6367	60.40	-11287	100.5	19	10	0	-17.1	0.5	0.20		

160 80 60 40 30 20 17 15 12 10 6

BP Stop Monitor Erase Clear Avg Avg 10 Decode **Enable Tx** Halt Tx

3cm **10.368,100 000**

H DX Call DX Grid  
 FT8 IZ4BFA JN54  
 FT4 Az: 142 849 km  
 MSK Lookup Add Ignore  
 Q65  
 JT65  
**Echo**

Fixed Tone  
 Message Spacing 10 Hz  
 CW

Tx: ECHO Echo 0 Last Tx: CQ ON4CDU JO20

# Samenvatting

- Opzetten van een EME station is een mechanische en technische uitdaging
- 10 GHz EME kan met relatief kleine antennes gedaan worden
  - Veel aandacht besteden aan optimaliseren
  - Zon- en maanruis meten
  - Minimaal een 100/120 cm schotel en 15 Watt output
- EME stations ontvangen kan ook met een kleinere opzet
  - Begin met de ontvangst van DL0SHF



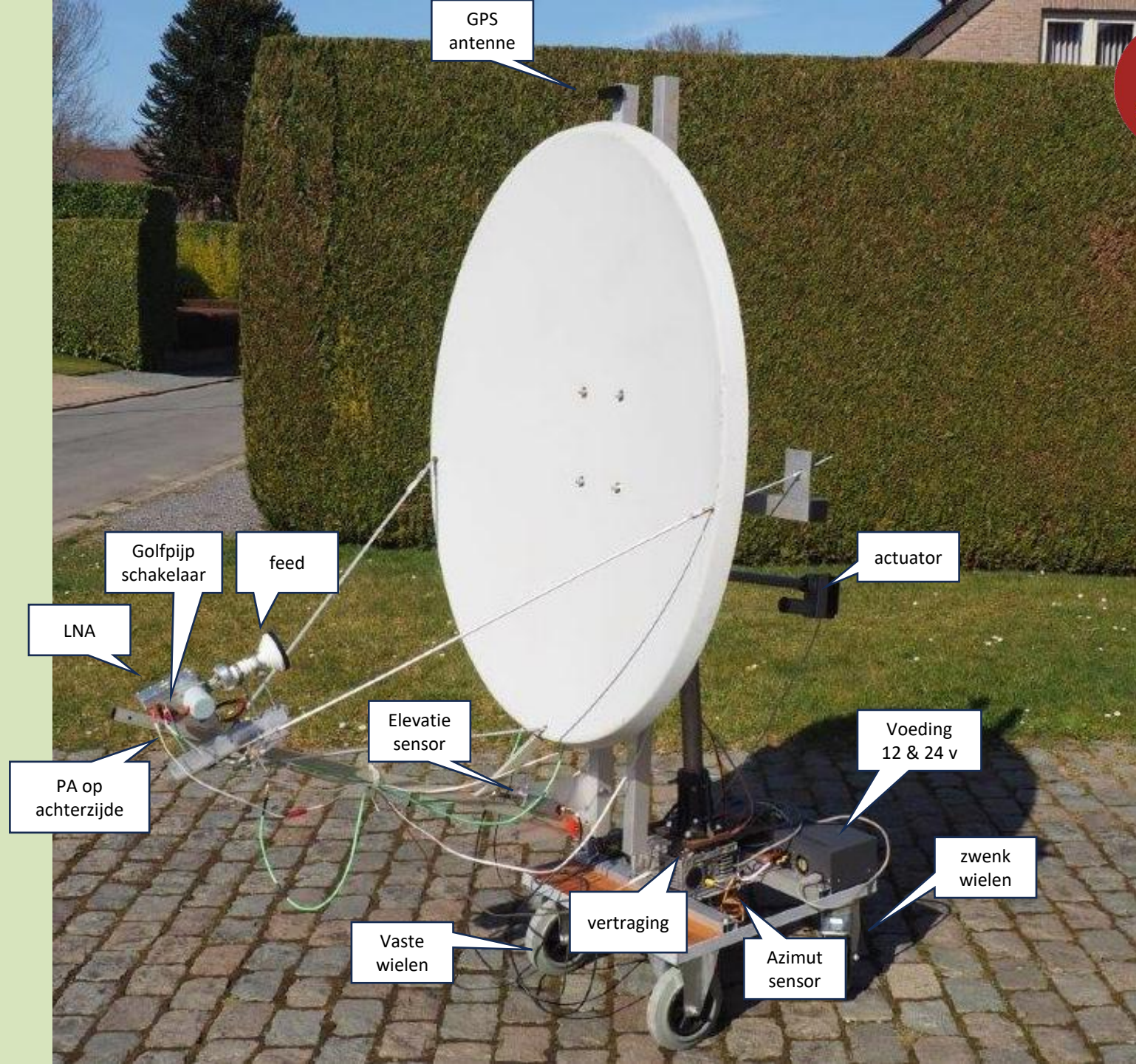

GPS  
antenne

Golfpijp  
schakelaar

feed

LNA

PA op  
achterzijde

Elevatie  
sensor

Vaste  
wielen

vertraging

Azimut  
sensor

actuator

Voeding  
12 & 24 v

zwenk  
wielen

# Websites

- [Moon-Net@ggroups.io](mailto:Moon-Net@ggroups.io) (forum)
- <https://hb9q.ch/> (chat)
- WSJT-x
  - <https://wsjt.sourceforge.io/wsjtx.html>
  - <https://sourceforge.net/projects/wsjt-x-improved/>
- EME newsletter
  - <https://eme.radio/432-and-above-newsletter>
- Algemeen
  - <https://www.bobatkins.com/radio/index.html>



**PA0HRK**

**Schotel: 1,1 meter**

**PA: 30 Watt**



**SA51KN portable 10 GHz EME  
(0.9m, 27W, 0.6dB NF)**



**NJ6D/P**

**Schotel: 1 meter**

**PA: 10 Watt**

**IZ2DJP**

**Schotel: 1 meter**

**PA: 12 Watt**



**Het is nu tijd voor**



# Deel 2

- Een aantal onderwerpen gedetailleerd
  - Signaal overdracht berekening
  - Q65 protocol nader bekeken
  - Dish en stralers
  - Antenne tracker details

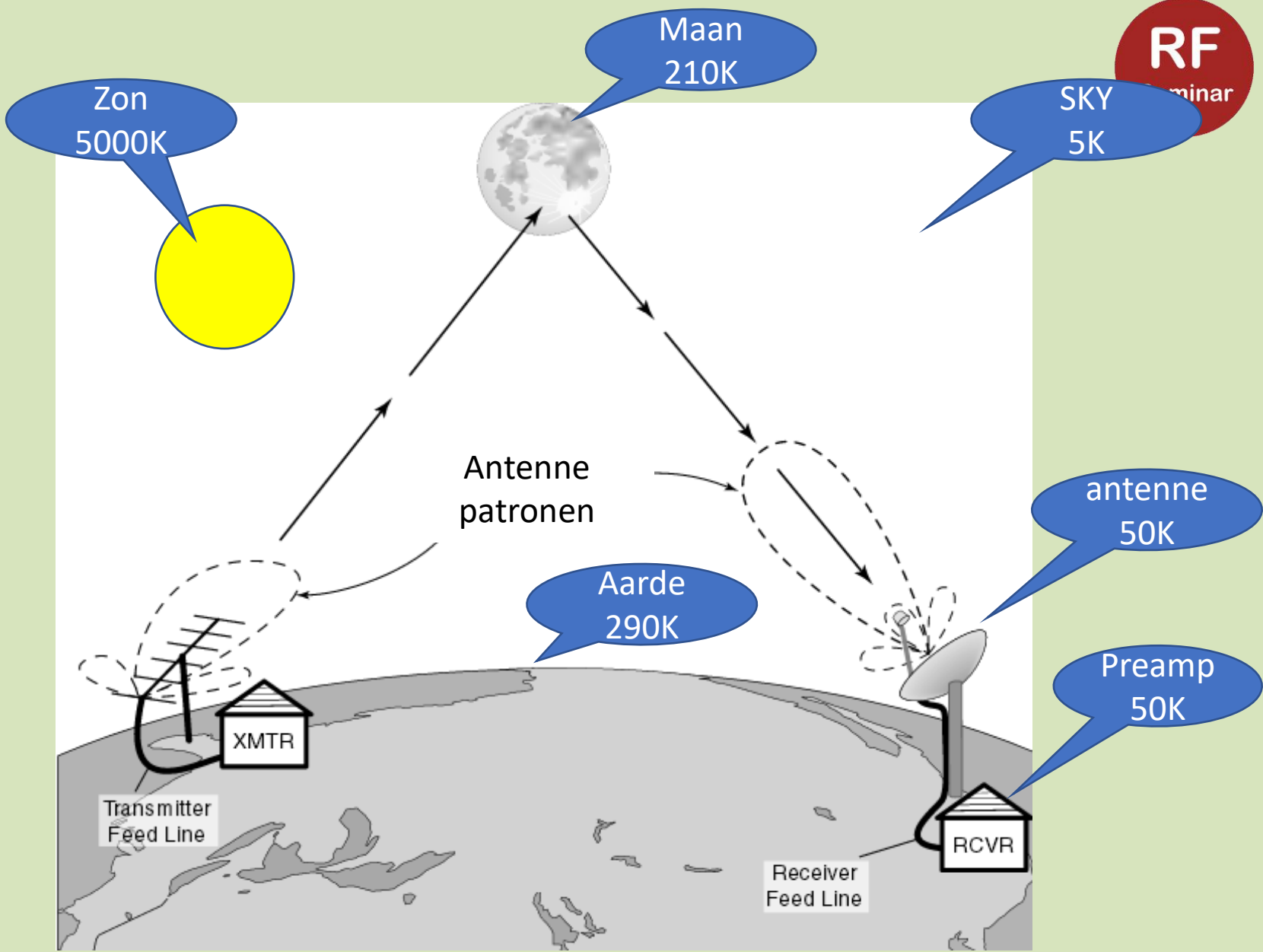

# Radar formule

$$P_{rec} = P_t G^2 \left( \frac{\lambda}{4\pi R} \right)^2 \frac{\sigma}{4\pi R^2}$$

range loss  
between transmit  
antenna & target
loss due to  
target reflection  
& range

De maanreflectiefactor: ~ 7%

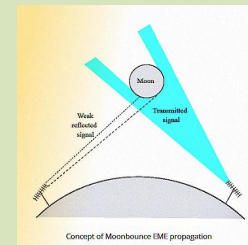

Note: bij een 1,2 m schotel gaat het meeste uitgestraalde vermogen langs de maan; slechts 0,064 deel draagt bij tot de reflectie!

$$P_{rx} = P_{tx} + G_{a_{tx}} + G_{a_{rx}} - 289 \text{ dB}$$

$$P_{rx} = 45 \text{ dBm} + 40 \text{ dB} + 40 \text{ dB} - 289 \text{ dB} = -165 \text{ dBm}$$

# Ruistemperatuur en ruisgetal

$$\text{Noise Temperature (K)} = T_{REF}(K) \times \left[ 10^{\frac{NF (dB)}{10}} - 1 \right]$$

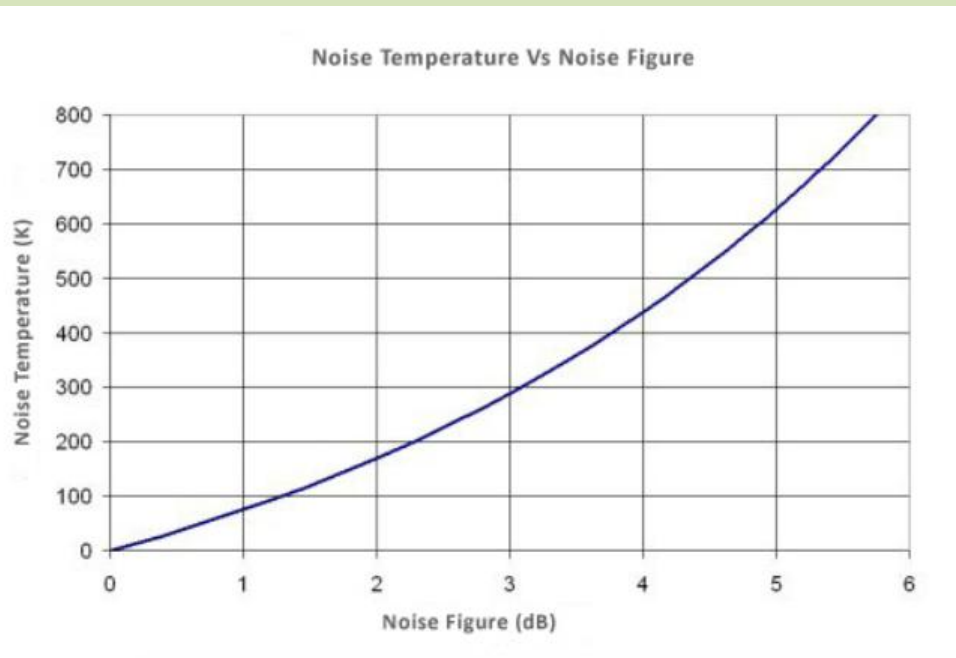

0.2 dB → 14K

0.3 dB → 21K

0.4 dB → 28K

0,5 dB → 35K

0,6 dB → 43K

0,7 dB → 51K

0,8 dB → 59K

0,9 dB → 67K

1.0 dB → 75K

Voorbeeld

Preamp: 0.7 dB = 51K

Waveguide relais 0.2 dB = 14K

Instraling: 0.5 dB = 35K

Maanruis: 0.5 dB = 35K

Totaal = 135 K

$$P_{rx} = kTB$$

$$\circ 1,4 \times 10^{-23} \times 135 \times 2500 = 4,7 \times 10^{-18} \text{ W} = -143 \text{ dBm}$$

# Ontvangst

- Ontvangen signaal  $-165 \text{ dBm} - -143 \text{ dBm} = -22 \text{ dB}$  onder de ruisvloer  
(in 2500 Hz bandbreedte)

Met WSJT-x protocol Q65 60D is een verbinding te maken!

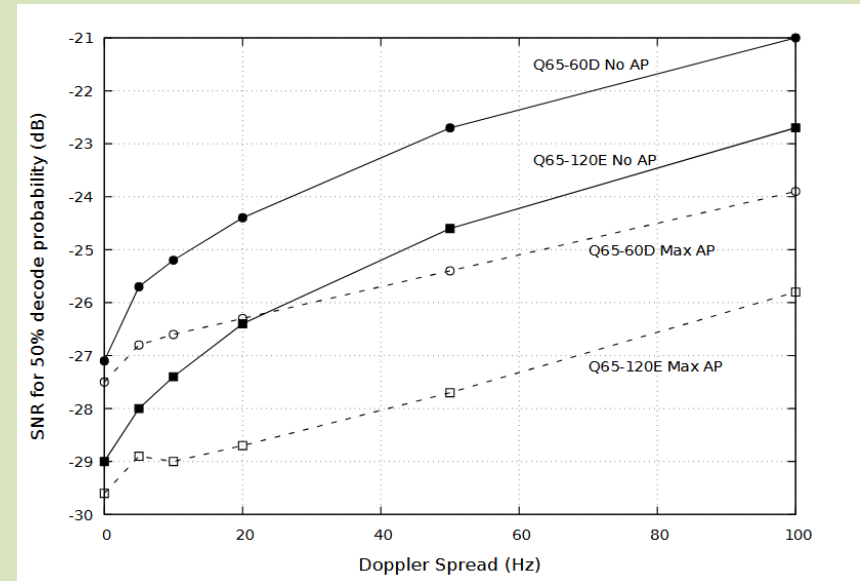

Voor een meer nauwkeurige analyse:

EME Link Budget & Analysis Tool (1 - 300 GHz) of VK3UM EME perf. calculator

<https://wetersat.bplaced.net/EME/EME.html>

<https://www.vk5dj.com/doug.html>

# VK3UM EME calculator

<https://www.vk5dj.com/doug.html>



VK3UM EME Performance Calculator Ver 11.11 UTC Date 29th januari 2026

Two Station EME | Rx Performance | Source Pos. | Planets | Sky Map | Home Data

### Tx A (Home Station)

Frequency: 1296 MHz | Path Loss: 270,20 dB | Rx BW: 10 K | Diam: 2,92 mm | Mesh: 10,00 mm | Spacing H-V: 10,00 mm | Sys Sensitivity: -161,6 dBm | Echo S/N: 26,17 dB

Effective ground 256 K

Loss 0,013 dB | Mesh Gad to Cold Sky > | 8,26 dB

75 | 0,10 dB | 0,25 dB | 38,0 dB | 2,0 dB | 1,0 dB | 7,08 K | 0,42 K | 21,95 dB

Get sfu | LNA Loss | LNA NF | LNA Gain | Coax Loss | Rx NF | Spillover | Feedthrough derived from Mesh size | Sun Y | 0,98 dB

Tx A Output Power: 560 Watts | 27,48 dBW | Transmission Loss: 0,3 dB | Power at Feed: 523 Watts | 27,18 dBW | 4.439.146 W EIRP | Moon Y

RxTK 24,39 K = 0,35 dB | Receiver Noise Temperature | Ground Temperature: 290 K 17 °C | TSys 41,89 K = 0,59 dB | System Noise Temperature

Dx Station as received at Home Station 3,01 dB | Change Moon Distance | Moon noise included | Perigee 383,118 kms | Apogee

Home Station as received at Dx Station 14,04 dB

### Tx B (Dx Station)

Frequency: 1296 MHz | Path Loss: 270,20 dB | Rx BW: 10 K | Diam: 2,92 mm | Mesh: 10,00 mm | Spacing H-V: 10,00 mm | Sys Sensitivity: -159,0 dBm | Echo S/N: -9,12 dB

Effective ground 236 K

Loss 0,013 dB | Mesh Gad to Cold Sky > | 8,26 dB

75 | 0,10 dB | 0,35 dB | 33,0 dB | 2,0 dB | 1,0 dB | 34,10 K | 0,42 K | 9,50 dB

Get sfu | LNA Loss | LNA NF | LNA Gain | Coax Loss | Rx NF | Spillover | Feedthrough derived from Mesh size | Sun Y | 0,06 dB

Tx B Output Power: 30 Watts | 14,77 dBW | Transmission Loss: 0,3 dB | Power at Feed: 28 Watts | 14,47 dBW | 21.440 W EIRP | Moon Y

RxTK 31,81 K = 0,45 dB | Receiver Noise Temperature | Ground Temperature: 290 K 17 °C | TSys 76,33 K = 1,01 dB | System Noise Temperature

### Yagi Array

Single Yagi Gain in dBd: 16,00 dBd | Number of Yagis: 1 | G/T: 0,00 | E: 26,04 ° | Beam Width: 26,04 ° | Array Type and Gain: User Defined | 18,15 dBi

### Parabolic Reflector

Focal length 3,68 m | Feed Type: W2IMU dual-mode | Linear Pol. | Circular Pol. | Diameter: 8,55 m | Size: Metric | f/D: 0,43 | Efficiency: 63,2% | Beam Width: 1,89° | Gain: 8494 | Dish Gain: 37,14 dBd | 39,29 dBi | 37,0 Lambds

### Home Station ... Y Factor Calc

Noise Source (Hot): Sagittarius A, Cassiopeia A, Cygnus A, Centaurus A | Taurus A, Virgo A, Termination | Noise Source Flux: 1718 Jy | Quiet [cold] Sky: 10 K | System TK: 41,89 K | Point Source Y Factor: 1,87 dB

YU1AW Aperture Source calculations. These are only valid for 144 and 432 MHz. Point Sources should be used for 1296 MHz and above.

### Yagi Array

Single Yagi Gain in dBd: 12,00 dBd | Number of Yagis: 1 | G/T: 0,00 | E: 41,27 ° | Beam Width: 12,00 dBd | Array Type and Gain: User Defined | 14,15 dBi

### Parabolic Reflector

Focal length 1,07 m | Feed Type: VE4MA (Super) | Linear Pol. | Circular Pol. | Diameter: 2,49 m | Size: Metric | f/D: 0,43 | Efficiency: 67,2% | Beam Width: 6,50° | Gain: 766 | Dish Gain: 26,69 dBd | 28,84 dBi | 10,8 Lambds

Parameter	TxA	TxB
Effective Aperture	38,17 M²	3,28 M²
Beam Width Ratio	0,29	0,08
Moon Beam Fill Factor	1,03	0,13dB
Sun Beam Fill Factor	1,00	0,01dB
G/T Ratio	202,77	23,07dB
Moon Radar Eq.	52,43 dB	
Current Moon Distance	363,116 kms	
Moon Angular Diam	0,548°	32'54,5"
Moon Temp		225 K

Operating Frequency: Click to enter a User Frequency

Save Data | Get Data | Default | Print

# OZ9AAR SimpleCalc

<https://moonbounce.dk/hamradio/simplecalc.html>

SimpleCalc - Cascaded noise figure and sun noise calculator. By OZ9AAR V.1.0.0.11

File Get SFU data.. Measure noise.. Two station echoes.. Settings.. About..

Antenna ohmic losses (dB):  0.000 K

Ta(K):

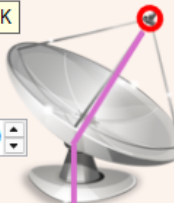

Gain (dBi):

Enable crosscheck

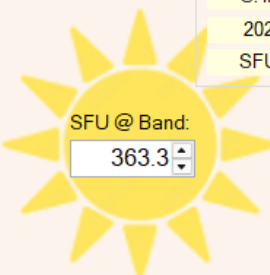

SFU @ Band:

SFU data

S. Italy - San Vito  
2026-02-07 1200  
SFU 10.7 cm: 154

Band

- 50 MHz
- 144 MHz
- 222 MHz
- 432 MHz
- 900 MHz
- 1296 MHz
- 2304 MHz
- 3456 MHz
- 5760 MHz
- 10368 MHz
- 0 MHz

Results

Receiver NF/temperature (from antenna connector to radio)	0.804 dB
	59.00 K
Overall NF/temperature (incl ohmic losses and Ta):	1.16 dB
	89.00 K
Figure of merit, M (G/T):	20.51 dB(K <sup>-1</sup> )
Expected Y-Sun level:	10.35 dB
Current Az/EI of sun:	249.28° 42.31°

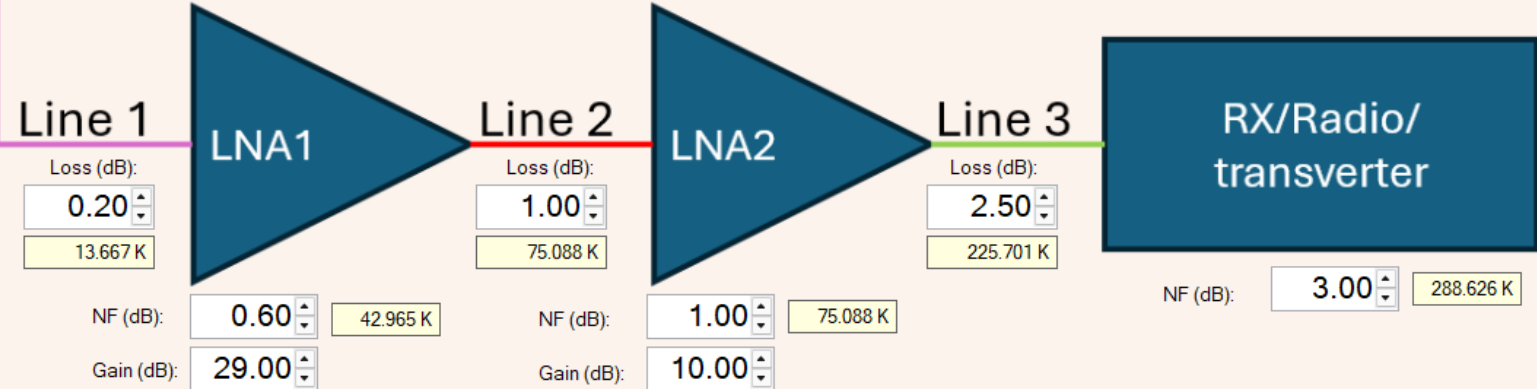

**Line 1** Loss (dB):  13.667 K NF (dB):  42.965 K Gain (dB):

**LNA1**

**Line 2** Loss (dB):  75.088 K NF (dB):  75.088 K Gain (dB):

**LNA2**

**Line 3** Loss (dB):  225.701 K NF (dB):  288.626 K

**RX/Radio/transverter**

# Standaard QSO – a priori (AP)



Aanroep

CQ PA0ABC JO12

Antwoord van station xxx

PA0ABC W9XYZ EN37

Rapport geven

W9XYZ PA0ABC -22

Rapport krijgen

PA0ABC W9XYZ R-19

OK verzenden

W9XYZ PA0ABC RRR

Afscheid nemen

PA0ABC W9XYZ 73

# Informatie pad

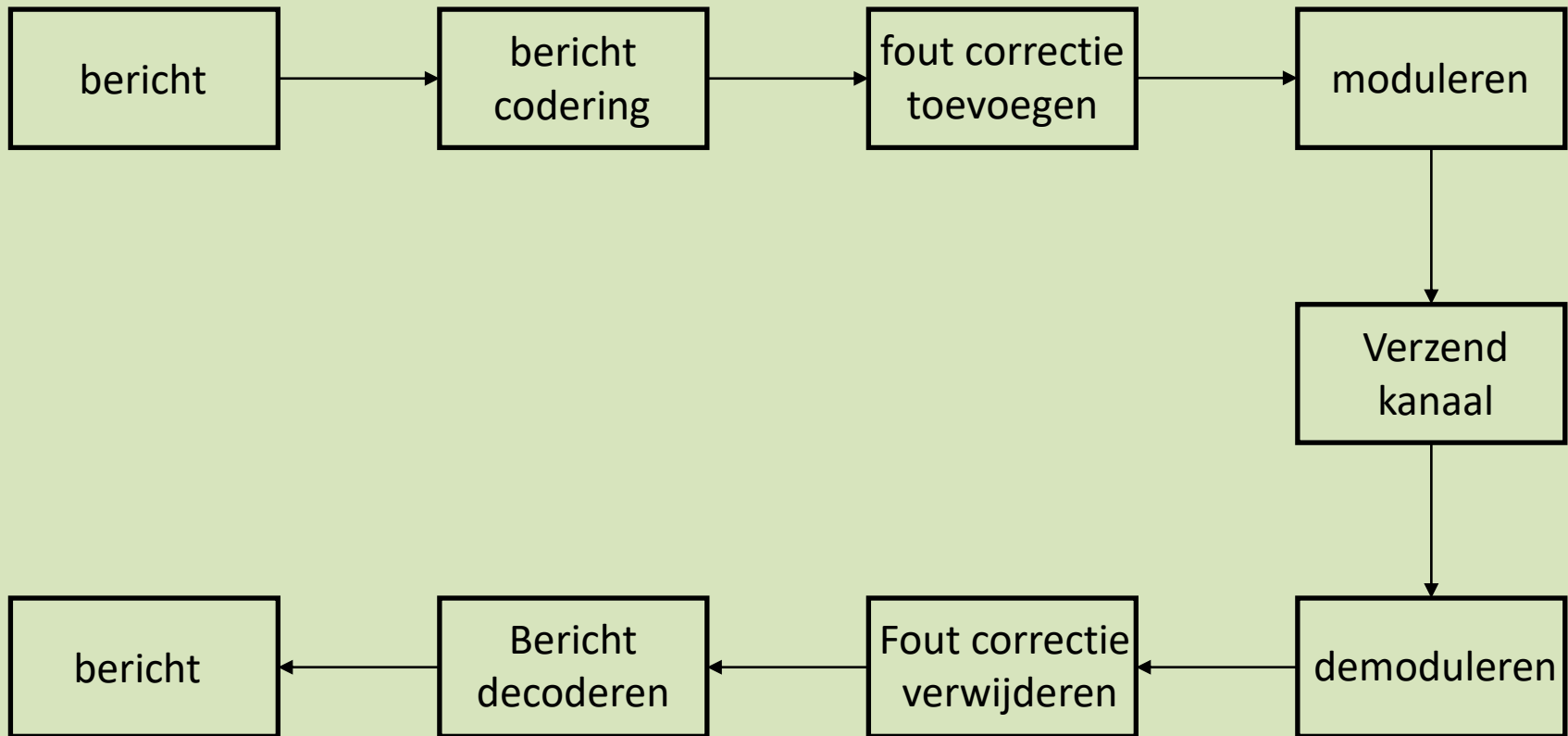

# Q65

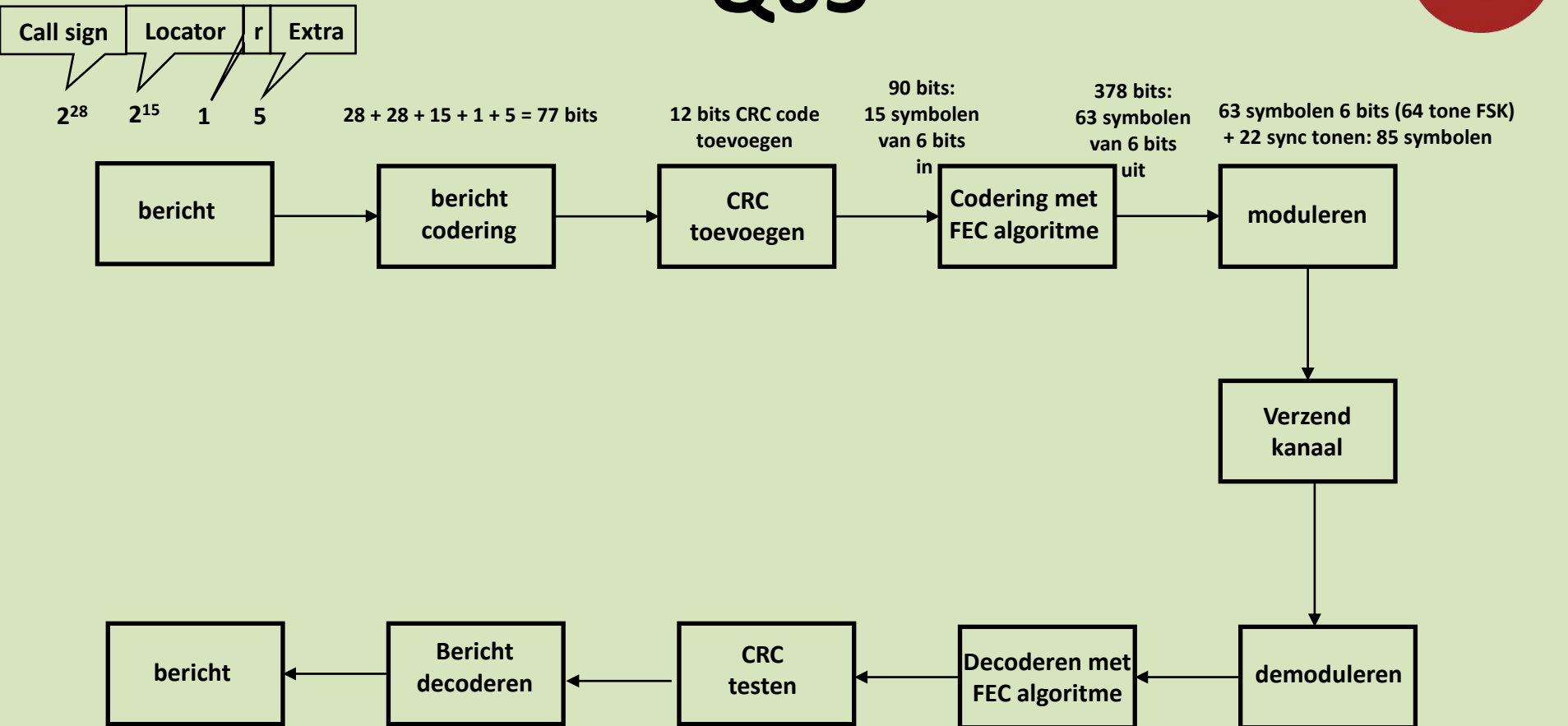

T/R Period (s)	A		B		C		D		E	
	Spacing (Hz)	Width (Hz)	Spacing (Hz)	Width (Hz)	Spacing (Hz)	Width (Hz)	Spacing (Hz)	Width (Hz)	Spacing (Hz)	Width (Hz)
15	6.67	433	13.33	867	26.67	1733	N/A		N/A	
30	3.33	217	6.67	433	13.33	867	26.67	1733	N/A	
60	1.67	108	3.33	217	6.67	433	13.33	867	26.67	1733
120	0.75	49	1.50	98	3.00	195	6.00	390	12.00	780
300	0.29	19	0.58	38	1.16	75	2.31	150	4.63	301

# f/D verhouding

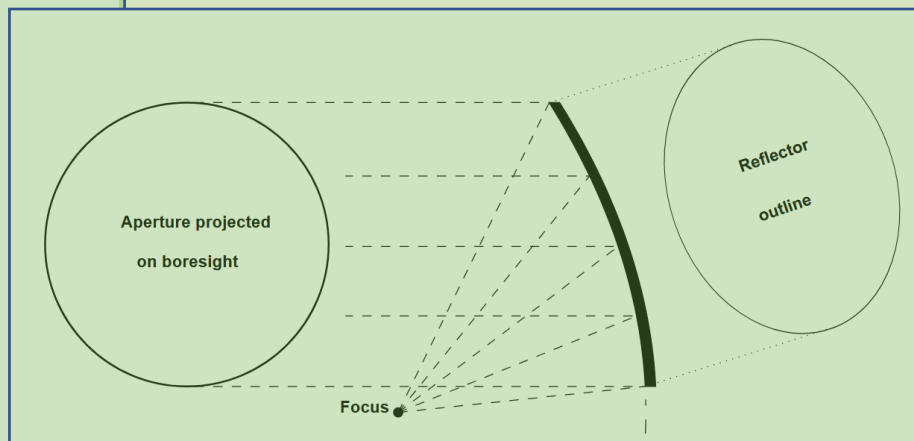
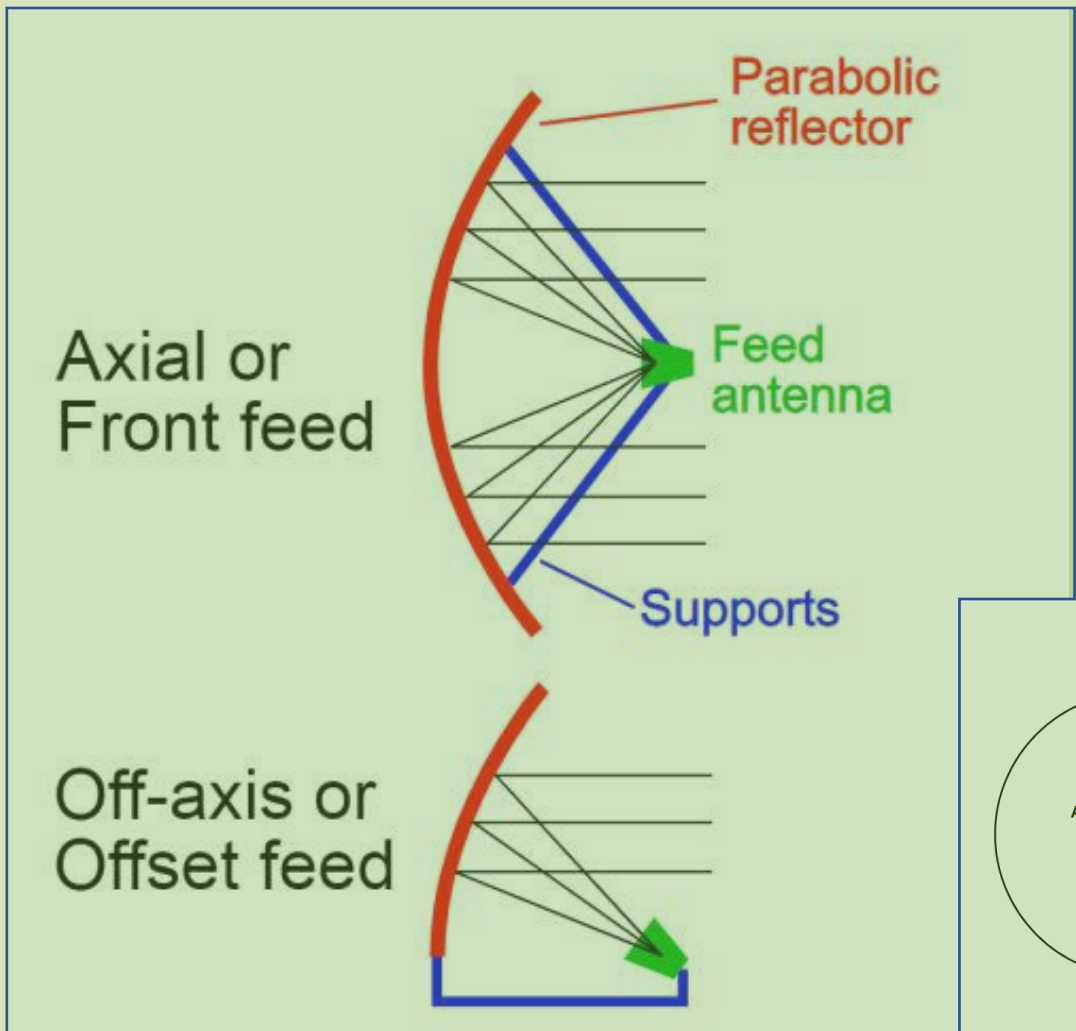

# Enkele stralings patroon opmerkingen

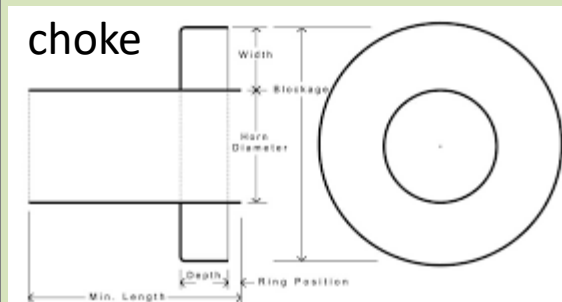
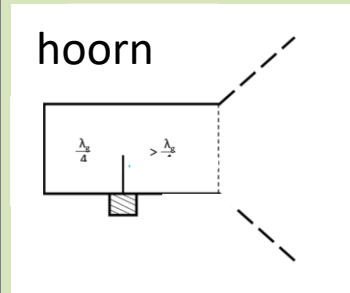
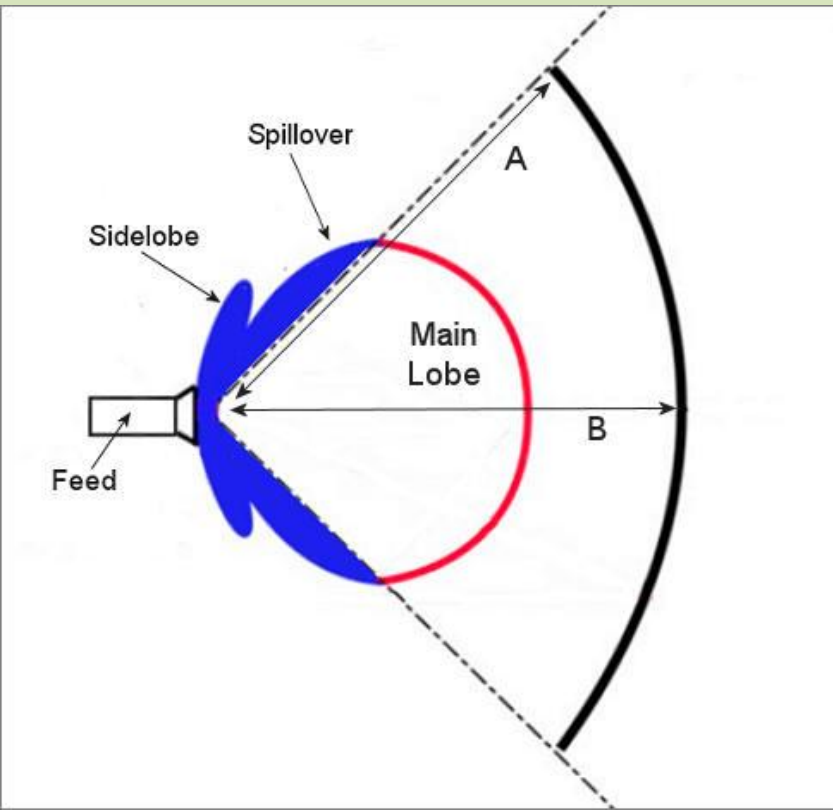
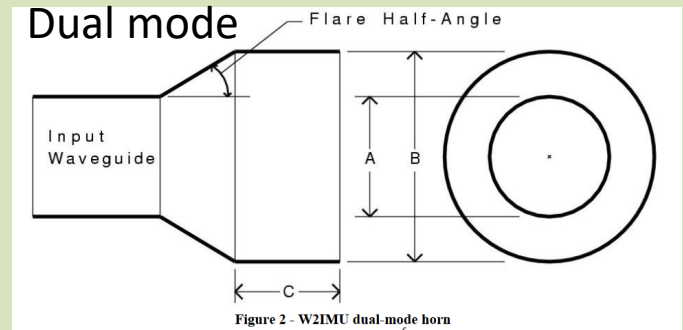
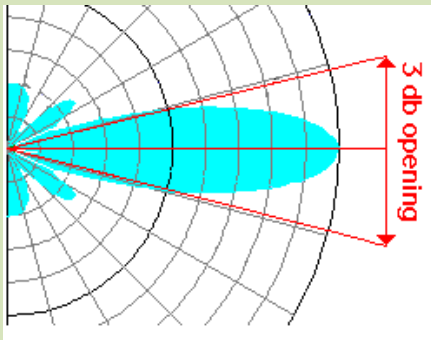

Figure 2. VE4MA (Kumar) Feed

# Offset Feedhorn $f/D \sim 0.6$



Рисунок 3: Чертеж и размеры

- Feedhorn origine Chanel Master ( Andrew , Skyware )
- Uitgeboord naar 20,5 mm
- Kwart golflengte transformator naar WR90 naar ontwerp RW3BP

Dank aan  
Eddy, ON7UN

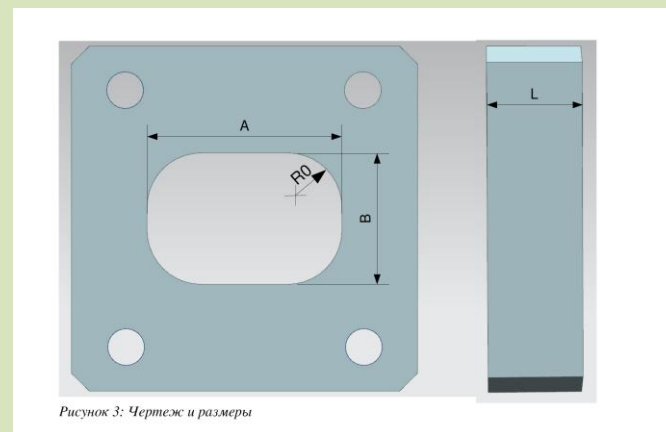

# 10 GHz W2IMU dual-mode hoorn for $f/D$ 0.67

ontworpen volgens de publicaties van W1GHZ

<b>A: Input circular waveguide</b>	Diameter 21,0 mm
<b>B: Aperture</b>	Diameter 45,527 mm
<b>C: Output phasing section</b>	Length 73,307 mm
<b>D: input waveguide</b>	Length tbd (e.g. 25 mm)
<b>Flair half-angle</b>	28,33 degrees

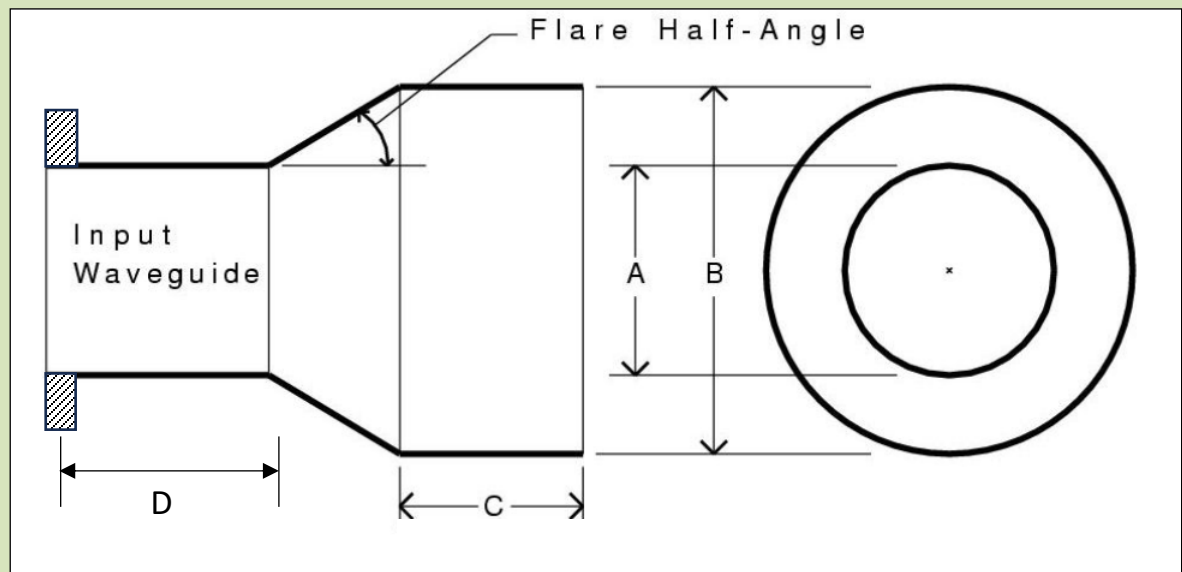

# W2IMU feed



# Feed in de schotel

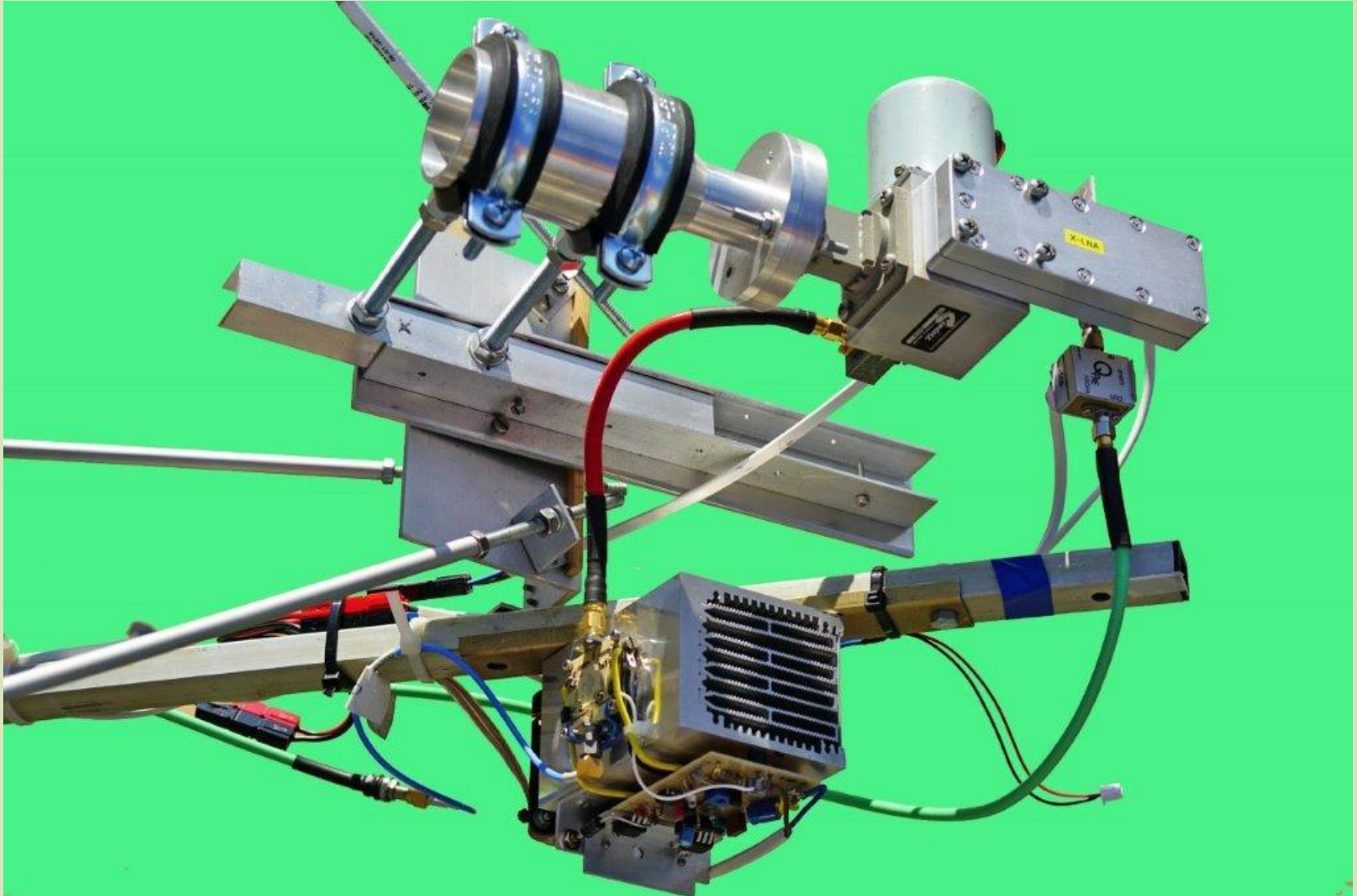

# Antenne tracking unit

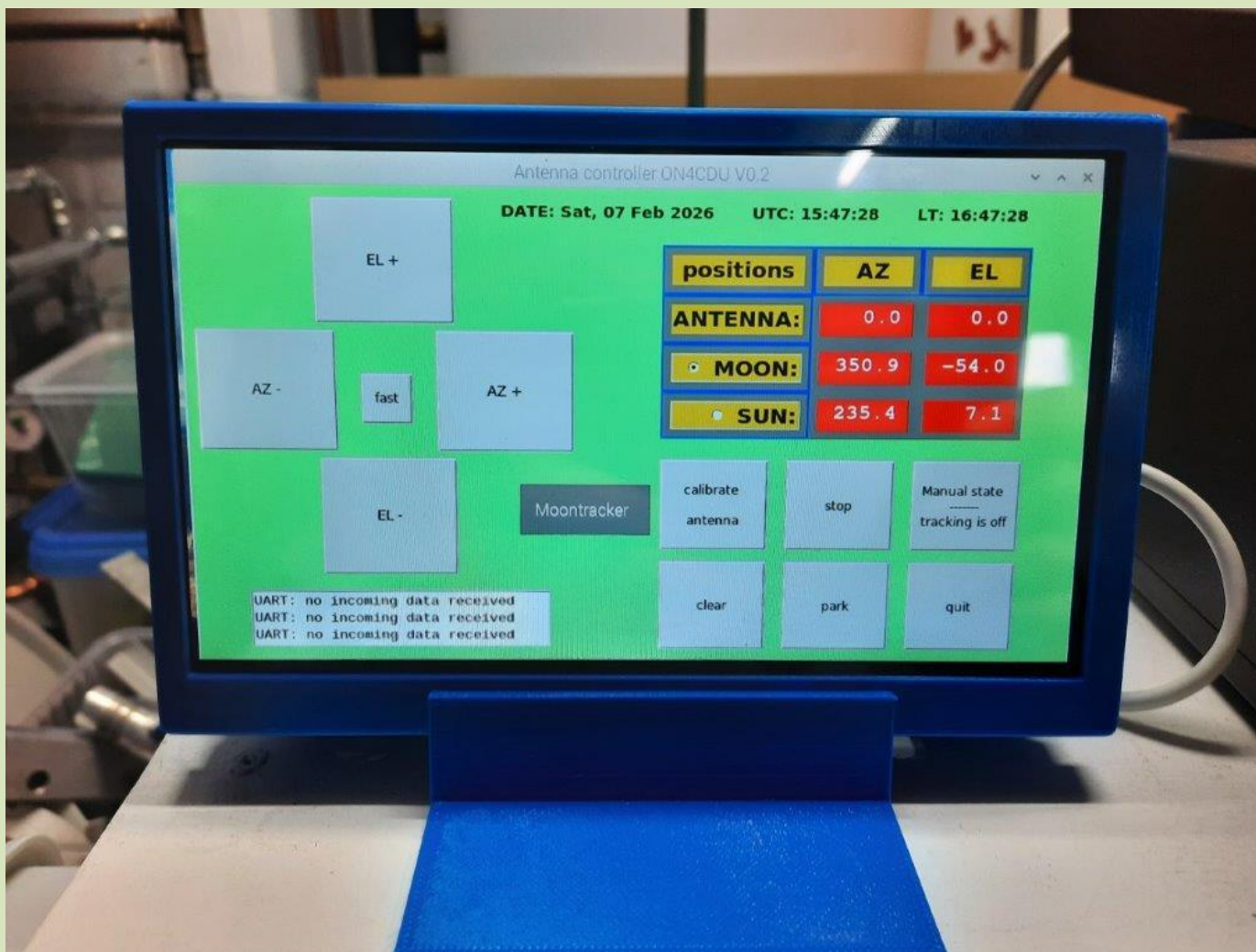

# Software Raspberry Pi

- **PI OS**
  - Configureren Wifi, GPIO, remote access, ...
- **Python 3**
  - Ephem (astronomische berekeningen)
  - Threads (voor sensor data)
  - Tkinter (HMI)
  - GPIO (sensor data input, motor sturing output)

# Software tracking Unit

De software, geschreven in Python, in grote lijnen:

- Berekening van de positie van de maan. De maan positie wordt bepaald met de UTC tijd en de positie van de waarnemer
- Lezen van de antenne positiedata: uitlezen van de data die op de UART binnenkomt
- Bijsturen van de antenne positie: maan (of zon) en antenne positie worden vergeleken. Bij grote afwijkingen wordt de antenne snel gedraaid; bij kleine afwijking wordt met PWM signalen de motor langzaam in positie gebracht
- Display van informatie: Tkinter wordt gebruikt voor het vertonen van data en voor het voor het lezen van opdrachten van de gebruiker

# Mockup

Antenna controller ON4CDU

Date:                      UTC:                      LT:

**AZ+**

**EL-**                      **EL+**

**AZ-**

**ANTENNA**

**MOON**

**SUN**

**AZ**                      **EL**

calibrate antenna      stop      tracking is off

clear                      quit

[Empty input field]

# Eind resultaat

Antenna controller GN4CDU V0.2



DATE: Wed, 11 Feb 2026

UTC: 15:44:59

LT: 16:44:59

EL +

AZ -

fast

AZ +

EL -

positions	AZ	EL
ANTENNA:	0.0	0.0
MOON:	280.5	-45.8
SUN:	235.6	8.5

calibrate antenna

stop

Manual state  
-----  
tracking is off

clear

park

quit

```
UART: no incoming data received
UART: no incoming data received
UART: no incoming data received
```

# That's all

## It is time for questions

